

ZAMIL STEEL



Product Brochure

Pre-engineered steel buildings

MaxSEAM[®] roof system

Structural steel

Content

CHAPTER 1: COMPANY PROFILE	3
Zamil Steel Buildings Vietnam - General Introduction	4
Sales Network	5
Zamil Steel Global Network	6
Certificates & Awards	7
Engineering	8
Manufacturing excellence and Machinery	9
High quality raw materials	11
Seamless quality assurance	13
Unparalleled services	19
CHAPTER 2: THE PRODUCTS	21
THE PRE-ENGINEERED STEEL BUILDINGS SYSTEM	22
Basic building parameters	24
Primary framing systems	25
Pre-Engineered Steel Buildings versus Conventional Steel Buildings	26
Crane systems	28
Flooring systems	29
Sub-Flooring Systems	32
Sub-Structural Systems	33
Secondary and bracing systems	35
Building accessories	36
Roofing, Wall Claddings, and Drainage Systems	37
Insulation	39
Ventilator Solution Systems	44
Examples of Pre-Engineered Steel Building Applications	45
MaxSEAM® - THE ULTIMATE ROOF SYSTEM	46
MaxSEAM® - Features	46
MaxSEAM® - Benefits	47
MaxSEAM® - Quality Test	48
MaxSEAM® - Clips	50
MaxSEAM® - Panels	51
MaxSEAM® - Re-roofing system	55
MaxSEAM® - Erection Procedures	57
STRUCTURAL STEEL	58
Zamil Steel's Strength	58
Workflow Chart	60
Examples of Structural Steel's Applications	62
CHAPTER 3: EXAMPLES OF MAJOR PROJECTS	63



ZAMIL STEEL

CHAPTER 1: COMPANY PROFILE



Zamil Steel Buildings Vietnam Co., Ltd

General introduction

Zamil Steel Vietnam is a premier steel structures supplier, with Saudi Arabia being the 100% investor. It specially designs, fabricates and erects steel buildings and structures applicable for a variety of sectors. With a supportive network of sales offices in Thailand, Philippines, Myanmar, Malaysia, Laos, Indonesia, Cambodia and Bangladesh, Zamil Steel Buildings Vietnam leads in manufacturing pre-engineered steel buildings and structures in the Asia-Pacific region, with two state-of-the-art manufacturing facilities in Vietnam.

Zamil Steel Buildings Vietnam serves the dynamic markets of Vietnam and Asia-Pacific, headquartered in a unique position in the capital city of Hanoi. Zamil Steel Buildings Vietnam has grown sustainably and successfully by consistently delivering superior quality steel buildings and structures for over two decades in this region, owing to its customized, complete solutions; longstanding engineering expertise; and manufacturing excellence.

Vision

To be the world's most reliable and innovative manufacturer, and the premier service and solution provider in the steel building industry.

Mission

To supply high-quality steel buildings and structures, providing related services and solutions to a worldwide client base while utilizing innovative technologies within an environment of motivated employees, focused on continuous improvement, highest business standards, work ethics and corporate citizenship, leading to added value for our customers and sustained return on investment to our shareholders.



North Vietnam - Hanoi Plant

located in Noi Bai Industrial Zone, Hanoi, Vietnam

Constructed in 1997, this plant specializes in the fabrication of pre-engineered steel buildings and heavy structural steel products.

Total Area: 41,200 m²

Fabrication Capacity:
5,000 metric tons (MT) per month



South Vietnam - Dong Nai Plant

located in Amata Industrial Zone, Dong Nai, Vietnam

Inaugurated in 2008, this new plant possesses the most up-to-date cutting-edge technologies and modern machinery for the fabrication of pre-engineered buildings and complex steel structures.

Total Area: 45,150 m²

Fabrication Capacity:
4,500 metric tons (MT) per month

Zamil Steel Buildings Vietnam Co., Ltd Sales Network

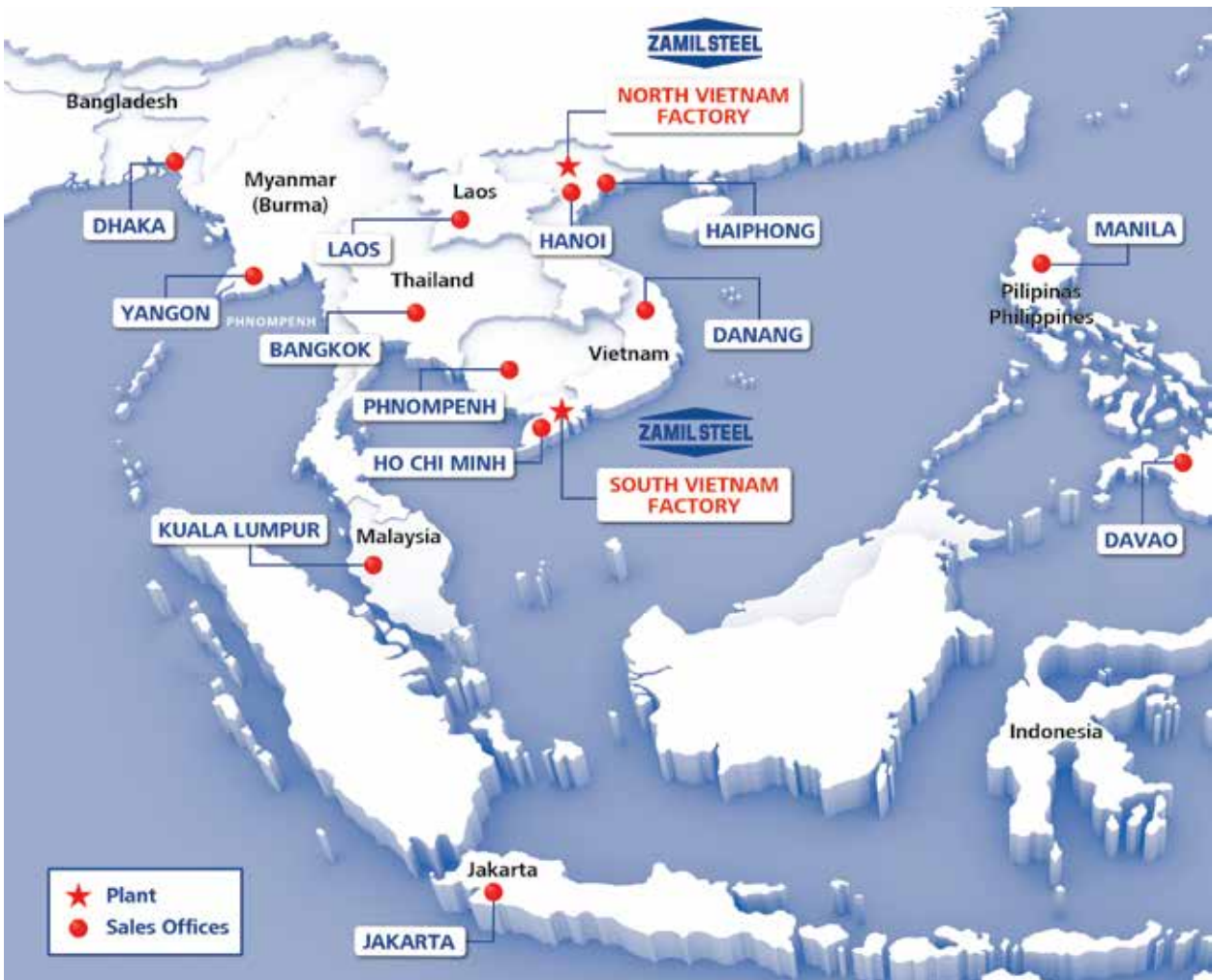
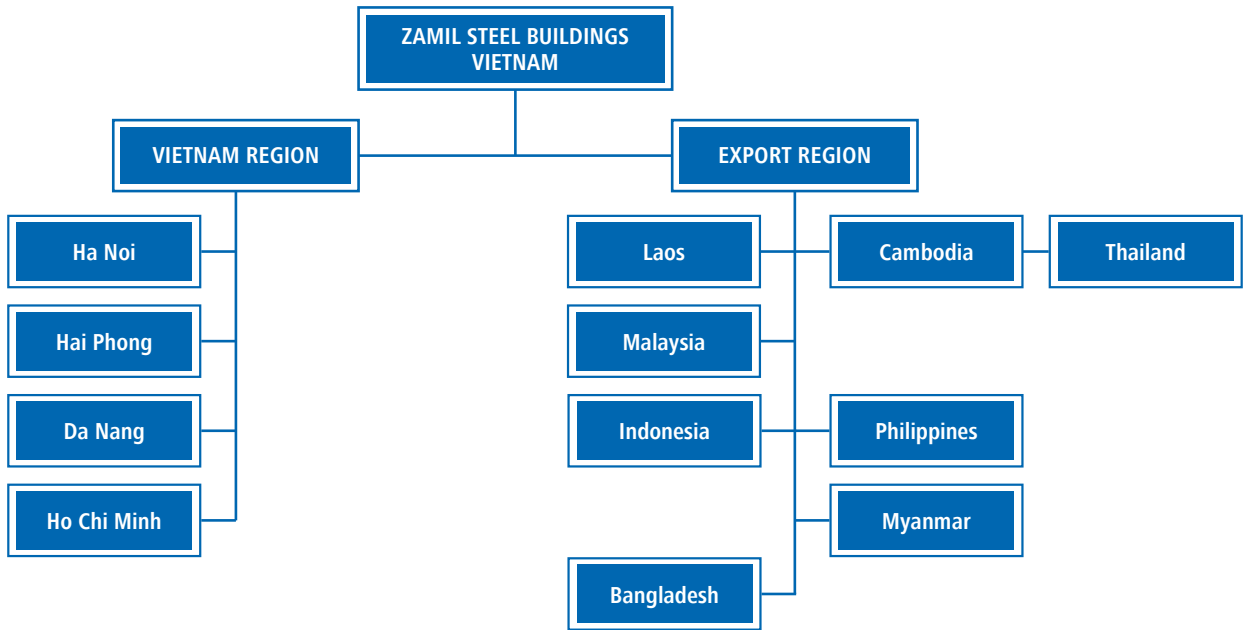

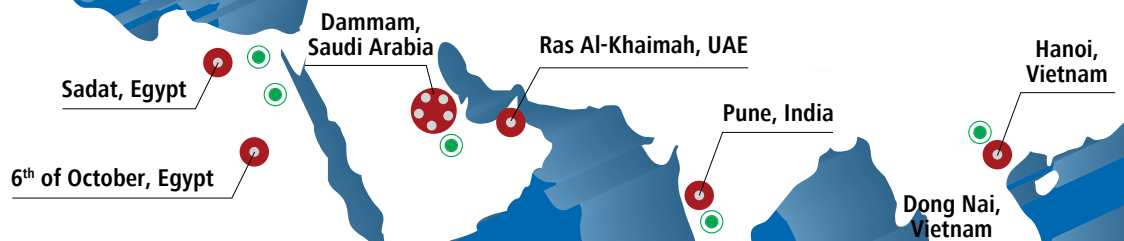

Zamil Steel Buildings Vietnam Co., Ltd

Zamil Steel Global Network

● Eleven Factories in

- Hanoi, Vietnam (1 plant)
- Dong Nai, Vietnam (1 plant)
- Dammmam, Saudi Arabia (5 plants)
- Cairo, Egypt (1 plant)
- 6th of October, Egypt (1 plant)
- Sadat, Egypt (1 plant)
- Pune, India (1 plant)
- Ras Al-Khaimah, UAE (1 plant)

● Eight Engineering Offices worldwide

- Hanoi, Vietnam
- HCMC, Vietnam
- Alexandria, Egypt
- Cairo, Egypt
- Chennai, India
- Dammmam, Saudi Arabia
- Kochi, India
- Pune, India

And 55 Representative Offices across Asia, Africa, Europe and Middle East

Zamil Steel Buildings Vietnam Co., Ltd Certificates & Awards



Investment License



Registration of Zamil Steel Trademark



Certificate of Construction Activity Capacity
(Vietnam)



ISO-9001



ISO-14001



ISO-45001



American Institute of Steel Construction
(AISC)
Certified Fabricator



FM Approval



Construction Research Institute of Malaysia
(CREAM)
Construction Product Approval Certificate

Zamil Steel Buildings Vietnam Co., Ltd

Engineering Expertise

Electronic connections support the collaboration of Zamil Steel's engineering groups located in six different countries, namely, Saudi Arabia, Vietnam, India, Egypt, Jordan, and UAE.

Being in the advantageous position of having erected over 70,000 steel buildings in more than 90 countries, Zamil Steel boasts the capacity to design considering all international codes and standards. With such unmatched proficiency, Zamil Steel ensures the best solutions to fulfill various functional, architectural and financial demands. Our team of talented engineers works meticulously in an industrial culture that promotes optimum resolution and precision. Such a unique, systematic, and consistent flow of design, process, and practical resolutions furnished by Zamil Steel renders it a global leader in the steel buildings industry.

Engineering codes

Unless otherwise required by local conditions, all of our steel buildings and steel structures are designed and manufactured in accordance with the latest editions of the following codes:

- **Low Rise Building Systems Manual**
Metal Building Manufacturer's Association, Inc. (**MBMA**)
- **Manual of Steel Construction Allowable Stress Design**
American Institute of Steel Construction, Inc. (**AISC**)
- **Cold Formed Steel Design Manual**
American Iron and Steel Institute (AISI)
- **Structural Welding Code-Steel Manual**
American Welding Society (AWS)
- **Minimum Design Loads for Buildings and Other Structures**
American Society of Civil Engineers (ASCE)

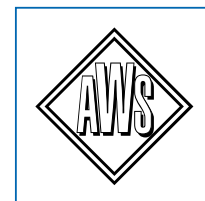

Engineering software

Zamil Steel Buildings Vietnam, since its establishment in 1997, has been actively involved in transforming complex constructions designed using conventional structural steel into simpler and more economical pre-engineered steel buildings without compromising on the qualitative, utilitarian and functional aspects of these buildings. Zamil Steel Vietnam has pioneered extraordinary progress in software development and computerization, intending to be the engineering leader in the steel buildings industry.

As of now, Zamil Steel's innovations have set such high standards in engineering that the rest of the steel buildings manufacturers aspire to achieve the same. All our engineering output, including design calculations, erection drawings, shop details, and bills of material, is 100% delivered in digital formats.

Engineering programs used include the following proprietary software:

- ASFAD (Advanced Steel Frame Analysis and Design)
- EZ BUILD (Automatic Generator of Design Calculation, Estimation, and Approval Drawings)
- EZ Detailer
- PES (Project Estimation System)
- Connection Design (RAM Connection/IDEA StatiCa)
- TEKLA (Structural Detailing Software)
- SUCHI (Supply Chain Internal)
- SAP 2000
- STAAD PRO

Zamil Steel Buildings Vietnam Co., Ltd

Manufacturing Excellence

More than 40 years of industrial experience and worldwide technical excellence support our manufacturing facilities, which rank among the most advanced in Southeast Asia, to confirm high production efficiency. Regardless of the projects' locations, be it in Vietnam, Southeast Asia, or anywhere else in the world, we promptly deliver top-quality finished products to our clients.

Our engineering proficiencies enable us to market a diversified range of products, including pre-engineered steel constructions, complementary MaxSEAM® roof systems, and the most complicated steel structures. Zamil Steel Buildings Vietnam is adequately furnished to cater to the clients' needs for total steel erections that satisfy their expectations as far as their quality and functionality are concerned.

Machinery list

No.	Machinery List in Hanoi factory	Quantity
1	Shearing machine Material Capacity: 20mm plate thickness, 6020mm plate length; Model No.: HACO PSC 6020	1
2	Shearing Machine 0.6M	1
3	Shearing machine Material Capacity: 20mm plate thickness, 6000mm plate length; Model No: QC11Y-20x6000	1
4	Crank press for Slot punching machine Model No. PC-5 (IV)	1
5	Movable slot punching machine	2
6	Beam straightening machine Model No. LTJ-800	1
7	Flange line	2
8	Flame Planer (FP- 4000E)	1
9	Punching machine (Puma 110S)	1
10	Iron worker machine (Hydracrop 110S)	3
11	Radial drilling machine (VO 50,60 DIA)	2
12	Auto welding machine line (SAW) Bay 3	1
13	Auto welding machine line (SAW) Bay 5	1
14	Full Weld station (FCAW)	18
15	Fitting weld Station	12
16	Vacuum lifter crane, Cap.5000lbs	4
17	MaxSEAM® roll former	3
18	Purlin roll former line: DTR	1
19	Sheeting Panel line – roll forming machine	1
20	MZ Profile Sheet Roll Forming Machine	1
21	Curb panel press brake	1
22	Panel cutting machine (hydraulic) type: MCT-0-8x1200	1

No.	Machinery List in Dong Nai factory	Quantity
1	Shear machine 350ton	1
2	New Shearing Machine	1
3	Vacuum Lifter For Shearing M.C	2
4	Slot punching machine	1
5	Movable slot punching machine	2
6	Flange line machine	2
7	Flame plane machine (multi torch cutting 7nos)	1
8	Flame plane machine (multi torch cutting 7nos)	1
9	Rod Bending MC	1
10	Rod threading MC	3
11	H-Beam Straightening machine	1
12	Ironworker GEKA 110ton	3
13	Ironworker GEKA 165ton	1
14	Hydraulic Ironworkers Machine 165 ton	1
15	Abrasive cutting disc	2
16	Radial drilling MC	2
17	Hydraulic Press brake 220ton	1
18	CNC Plasma Max 300	1
19	CNC Drilling MC 1250	1
20	CNC Band saw 1270	1
21	CNC Plate Drilling machine	1
22	CNC Coping MC	1

Zamil Steel Buildings Vietnam Co., Ltd

No.	Machinery List in Hanoi factory	Quantity
23	CNC Folding machine - Model No. SL300 MB4001-10	1
24	Down spout lock former	2
25	50x50 Angle steel with lip roll forming machine	1
26	Rod threading machine No. FE099 98	2
27	Press brake machine	1
28	Press machine (hydraulic) Model: WS-110	1
29	Slitting machine	1
30	Abrasive Disc cutting machine PN 2414 NB	1
31	Crank Shaft press machine (Korea)	1
32	Airless Spray painting machine Model: EXTREME KING 68:1 (2pcs) and Model: EXTREME KING 33:1 (3pcs)	5
33	LT-7.Auto-Fillet Welding Machine/Squirt mobile	3
34	Air compressor with dryer	3
35	Overhead crane 10MT (7pcs) and 5MT (14pcs)	21
36	Travel crane	6
37	Jib crane	20
38	Gantry crane	3
39	Shot blasting machine with accessories	1
40	Rod bending machine; Model No. BENDHOR-50	1
41	Magnetic drill 220V; Model: AO-3000; AO-3500; AO-5575; AO-5575A	8
42	PORTABLE AUTOMATIC GAS CUTTER; MODEL: IK-93 HAWK	2
43	PORTA-PUNCH 35 TON Model No.: HS11-1624	3
44	Fork lift 5 tons/ 10 tons	2
45	Side loader	2
46	CNC Drilling Machine FD-1635	1
47	Crankpress MC 15 tons/ 70 tons (Maxseam Clip)	7
48	Plate Straight Press MC	2
49	CNC Plasma Machine	1
50	Skids welding Station	1
51	Sundry welding Station	2
52	Machanism container pushing	2
53	H Beam Gas Cutting Machine Model: CG1-02	1

No.	Machinery List in Dong Nai factory	Quantity
23	CNC Folding machine JZW800 Digital Control Folder Slitter	1
24	Curb panel press brake	1
25	Hydraulic band saw	1
26	Bending canam MC	1
27	Shot Blasting & Peening machine	1
28	Airless spray painting machine (Graco)	5
29	Autoweld machine line	2
30	Tacking station machine	2
31	Seam Welding machine	2
32	Welding station MIC	60
33	Welding station Tack	20
34	Welding TIC	2
35	LT-7.Auto-fillet welding machine/Squirt mobile	5
36	Stud welding machine	2
37	Angle Splice line	1
38	CNC Angle Cutting Punching (Ficep)	1
39	Portable Rollformer (Maxseam® MC)	2
40	Overhead crane 15ton	3
41	Overhead crane 10ton	9
42	Overhead crane 5ton	9
43	Wall crane 2ton	19
44	Zip crane 2ton	2
45	Vacuum lifter crane 2ton	4
46	Transfer cart	2
47	Forklift 11ton	1
48	Forklift 5 ton	1
49	Plate Straing Press	4
50	SAW line (Off line)	4
51	C& Z Purlin & Slitting Machine	1
52	CNC Beam Drilling MC- AMG 350	1
53	Air - Compressor -90	3
54	Air- Dry MC	3
55	Sheeting MC	1

Zamil Steel Buildings Vietnam Co., Ltd

High quality raw materials



Structural Members

Structural Member	Material	Conforming to
Built-up sections (columns and rafters)	Hot rolled steel sheets & plates	ASTM A572M Grade 345 Type 1 (or equivalent) with a min. yield strength of 34.5 kN/cm ²
Hot rolled channel	Hot rolled sections	JIS G3101 SS400 (or equivalent) with a min. yield strength of 24.5kN/cm ²
Hot rolled beam	Hot rolled sections	JIS G3101 SS400 (or equivalent) with a min. yield strength of 24.5kN/cm ²
Interior columns	Mill formed steel tubes	JIS 3466 STKR 490 (or equivalent) with a min. yield strength of 32.5kN/cm ²
Pre-galvanized secondary members (Purlin and Girt)	Cold formed from steel coils	ASTM A653M SS Grade 340 Class 1 (or equivalent) with zinc coating to Z275 designation (275 g/m ²) with a min. yield strength of 34.0kN/cm ²
Bracing rods	Plain Round Bars	JIS G3101 SS400 (or equivalent) with a min. yield strength of 23.5kN/cm ²
Bracing Cables	Zinc coated extra high strength grade wire strand [275 g/m ² minimum coating]	ASTM A475 -03, class A. Extra high-strength grade with minimum breaking strength is 119.657 kN.

Panels

Panel	Material	Conforming to
Roof Panels	Roll formed from 0.5 mm thick cold-rolled steel coated with aluminum–zinc alloy (Zincalume). Pre-painted roof panels are also available	ASTM A792M SS Grade 340 class 2, Zincalume alloy coating AZM 150 having a min. yield strength of 34.0 kN/cm ² (or equivalent)
Wall Panels	Same specifications as the roofs, but they are mill painted. Paint finish film thickness shall be 25microns of high durability polyester (ZSP) on the exterior (weather) face and 12 microns of regular polyester on the interior face.	ASTM A792M SS Grade 340 class 2, Zincalume alloy coating AZM 150 having a min. yield strength of 34.0 kN/cm ² (or equivalent)

Zamil Steel Buildings Vietnam Co., Ltd

High quality raw materials



Trims and Gutters

Trims and Gutters	Finishing/Coating	Conforming to
Flashing and trims	Same as wall panels	Same as wall panels
Eave gutters and downspouts	Same as wall panels	Same as wall panels
Valley gutters	Cold formed from a 1.0 mm thick bare Zinalume coated cold-rolled steel coil	ASTM A792M SS Grade 340 class 2, Zinalume alloy coating AZM 150 having a min. yield strength of 34.0 kN/cm ² (or equivalent)

Bolts

Bolt	Finishing/Coating	Conforming to
High strength bolts (to connect primary members)	Hot-dip galvanized	ASTMA325 grade 8.8 (full thread), type 1, (or equivalent.)
Machine bolts (to connect purlins and girts)	Electro-galvanized with a yellow chromate color conversion coating	Din 933 Class 4.6 Yellow Chromate. (or equivalent)
Anchor bolt straight type	Electro-galvanized	JIS G3101 - SS400 (or equivalent), with minimum yield strength of 24.5 kN/cm ²

The raw materials for structural steel will be mainly hot rolled sections which to be procured as per specification indicated in the design of projects.

The hot rolled steel plates for connection are usually stocked in our factory which conforming to A572M SS Grade 345 (or equivalent) with a min yield strength of 34.5 kN/cm² .

Zamil Steel Buildings Vietnam Co., Ltd

Seamless quality assurance



Checking Incoming Materials



Dimension Checking



Welding Checking



Ultrasonic Testing



Magnetic Particle Testing



Liquid Penetrant Testing



Painting Checking



Final Checking

Zamil Steel Buildings Vietnam follows a stringent quality control program at each stage in its manufacturing process.

The company has an independent Quality Control Department, which coordinates with other departments to ensure that:

- Raw materials, consumables, and buyout inventories are received as per defined standards of quality.
- All products are produced in accordance with approved procedures to meet required Quality Level.
- Finished products are stored and shipped in safe and sound condition.

Zamil Steel Buildings Vietnam continuously strives to improve its products and process through statistical monitoring of the internal in-process non-conformances and customer complaints. A team of Inspectors closely watches every activity right from the review of shop drawings to the fabrication, welding, surface preparation, painting

and shipping stages of the manufacturing and delivery process.

The inspection procedures are well defined and documented in the Quality Plan, as per the recommendations of ISO 9001. The inspection record is traceable for two years, or a longer period, if requested by the client in a special contract.

Zamil Steel Buildings Vietnam is well equipped with facilities for in-house testing of steel for Hardness, Ultrasonic (UT), Magnetic Particle Testing (MPT), Liquid Penetrant Testing (PT). Mechanical, Chemical and X-ray tests are subcontracted to several locally present international testing agencies such as IBST, QUATEST 1&3, SGS, APAVE etc.

Zamil Steel Buildings Vietnam QC, UT, MT and PT Inspectors are qualified and trained as per the American Society for Non-Destructive Test Level II, III requirements.

All the welders at Zamil Steel Buildings

Vietnam are qualified to perform as per the approved welding procedures with reference to American Welding Society code AWS D1.1.

The QC Department also performs periodic quality audits, in line with ISO 9001 requirements.

1. Checking Incoming Materials
2. Dimension Checking
3. Welding Checking
4. Ultrasonic Testing
5. Magnetic Particle Testing
6. Liquid Penetrant Testing
7. Surface Preparation checking
8. Painting Checking
9. Final checking

Etc....

Zamil Steel Buildings Vietnam Co., Ltd

Seamless quality assurance

Following is a list of various equipments used for Quality Control at Zamil Steel:

No	Equipments	Application
1	PosiTector-DPM	To check the surface temperature
2	Measuring Tapes	To inspect the dimension of the product
3	Vernier Caliper	To measure thickness/diameter of incoming materials
4	Micrometers	To measure thickness/diameter of incoming materials
5	Ultrasonic Thickness Gauge	To check the thickness of materials
6	Welding Gauge	To inspect the size the weld profile
7	Ultrasonic Epoch III, Epoch XT & Epoch 4	To detect flaw in raw materials and weldment area, etc also to measure wall thickness of material
8	DFT gauge (Positector 6000 Coating Thickness Gauge)	To measure the thickness of paint coating
9	MPT Testing Yoke	To check surface welding surface
10	Surface Profile Gauge (Elcometer 223)	To measure surface anchor profile of blast cleaned steel
11	Cross Hatch Tester	To inspect paint adhesion after the coating fully dried
12	Surface Profile Comparator	To compare the profile of blast cleaned surface with standard pattern



A standard Quality Plan (QP), also referred to as the 'Inspection and Test Program' (ITP), as shown below is adopted for each job at Zamil Steel.

The ITP, works as a reference document and shows how much inspection needs to be carried out, at what stage, what standards / codes / tolerances shall be followed and what will be the reporting format. For complex jobs or when desired by a customer, the ITP is revised on job to job basis and approved by the customer.

Inspection & Testing Program (ITP)

MBMA:	Metal Building Manufacturers Association
UBC:	Uniform Building Code
AWS D1.1	Structural Welding Code - Steel
SSPC:	Steel Structures Painting Council
ASTM:	American Society for Testing and Materials
AISC:	American Institute of Steel Construction

Zamil Steel Buildings Vietnam Co., Ltd

Seamless quality assurance

Inspection and Testing Program for Pre-Engineered Steel Buildings

Test #	Nature of Inspection / Test	Extend of Insp. by ZSV	Acceptance Norm	Record Format	Inspection ZSV
1	QUALITY CONTROL SYSTEM IMPLEMENTATION	100%	ZSV QSM	CAR#ZMF 11	R / V
1.1	WPS / PQR / WQTR / WELD MAP/ NDT/ PAINTING				
1.1.1	Welding Procedure Specifications.	100%	AWS D1.1 - 2015	WPS/ PQR/ NCR#ZMF 12*	V
1.1.2	Welders /Welding Operators Qualification Records.	100%	AWS D1.1 - 2015	WQTR/ NCR#ZMF 12*	V
1.1.3	Weld map	100%	Shop Drawing	NCR # ZMF 12*	R
1.1.4	NDT Procedures / NDT Technician Certificates.	100%	AWS D1.1:2015	NCR # ZMF 12*	R
1.1.5	General Procedure for Surface Preparation & Coating	100%	Procedures	NCR # ZMF 12*	R
2	* PRE-INSPECTION MEETING (If required - Note 2) (Before commencement of the job)	One time		MOM	A
3	RAW MATERIAL INSPECTION				
3.1	Steel Plates/Shapes		ASTM A572/ Gr.345/SS400/ (or) Equivalent/P.O	P.O	
3.1.1	Verification of P.O. requirements.	100%	Material Specs./P.O	Report # QCF-01	I
3.1.2	Mill Test Certificate review.	100%	Material Specs./P.O	NCR # ZMF 12*	R
3.2	Fasteners: Bolts / Nuts / Washer				
3.2.1	Verification of P.O. requirements.	100%	ASTM/ ANSI	Report # QCF 01	I
3.2.2	TC & MTC review.	100%	DIN (931/933)/P.O	NCR # ZMF 12*	R
4	MATERIAL PREPARATION				
	Shearing / Gas Cutting, Machining, Sawing, Drilling or Punching, etc.				
4.1	Visual Inspection.	10% Min.	MBMA:2012/AISC-15th/SD	NCR # ZMF 12*	I
4.2	Dimensional Inspection.	10% Min.	MBMA:2012/AISC-15th/SD	NCR # ZMF 12*	I
5	FABRICATION AND FIT UP COMPONENTS				
5.1	Dimensional check of fit up components, holes, overall length, markings (Primary Members).	50% Min.	MBMA:2012/AISC-15th/SD	Report # QCF-03	I
5.2	Dimensional check of fit up components, holes, overall length, markings (Secondary Members, Sundries Parts).	10% Min.	MBMA:2012/AISC-15th/SD	Report # QCF-03	I
5.3	Dimensional check, Profile, Color & Visual Insp.: Sheets, Trims, Gutters, Purlins etc.	10% Min.	MBMA:2012/AISC-15th/SD	Report # QCF-04	I
6	IN-PROCESS WELDING INSPECTION				
6.1	Welding Consumables Receipt Inspection.	On every P.O.	AWS D1.1-2015 / P.O	Report # QCF 01	I
6.2	Verification of actual Welding Parameters.	10% Min.	WPS / PQR	NCR # ZMF 12*	V
6.3	Verification of Welders Qualification.	100%	WQTR	NCR # ZMF 12*	V

Zamil Steel Buildings Vietnam Co., Ltd

Seamless quality assurance

Test #	Nature of Inspection / Test	Extend of Insp. by ZSV	Acceptance Norm	Record Format	Inspection ZSV
7	NON-DESTRUCTIVE TESTING				
7.1	Visual Inspection (primary members)	50% Min.	AWS D1.1:2015	Report # QCF 05	I
7.2	Visual Inspection (secondary/sundry members).	10% Min.	AWS D1.1:2015	Report # QCF 05	I
7.3	Primary Built-up Members				
7.3.1	Butt welds - splice (Flange & Web). Thickness \geq 8 mm - UT	25% Min.	AWS D1.1:2015	Report # QCF 06	T
8	SURFACE PREPARATION & PAINTING				
8.1	Receipt Inspection of Abrasives, Paints, Thinner.	On every P.O.	P.O.	Report # QCF 01	V
8.2	Surface Cleaning (as per requirement).	10% Min.	SSPC / Job Spec.	NCR # ZMF 12*	V
8.3	Anchor profile (as per requirement).	10% Min.	SSPC / Job Spec.	NCR # ZMF 12*	V
8.4	Mixing / Application / Recoat / WFT.	10% Min.	SSPC / Job Spec.	NCR # ZMF 12*	W
8.5	Visual Inspection of Coatings.	50% Min.	SSPC / Job Spec.	NCR # ZMF 12*	I
8.6	Paint - DFT (as per requirement).	25% Min.	SSPC-PA2 / Job Spec.	Report # QCF 09	I
8.7	Marking.	5% Min.	SD	NCR # ZMF 12*	V
8.8	Touch up (Repair).	25% Min.	SSPC / Job Spec.	NCR # ZMF 12*	W
9	GALVANIZING*				
9.1	Zinc Quality & MTC Review.	100%	ASTM B6	NCR # ZMF 12*	V/R
9.2	Surface Cleaning - SP8 (Acid pickling).	5% Min.	SSPC / Job Spec.	NCR # ZMF 12*	I
9.3	Visual Inspection of Zinc Coating.	20% Min.	ASTM 123-17/Job Spec.	NCR # ZMF 12*	I
9.4	Zinc coating thickness - (As per ASTM 123).	10% Min.	ASTM 123-17	Insp.Rpt.# QCF 18 Galvanizer/ Certificate	I
9.5	Adhesion Test (Hammer or Stout Knife Test).	5% Min.	ASTM 123-17	NCR # ZMF 12*	T
9.6	Repair Galvanizing or Touch up.	20% Min.	ASTM 123-17	NCR # ZMF 12*	W
10	INSPECTION RELEASE CERTIFICATE (IRC)				
10.1	Pre-Shipment Inspection (** RFI)	10% Min.	Job Specifications	Report # QCF 10	I
10.2	Packing Inspection (Truck load).	10% Min.	Job Specifications	Packing List	I
11	DOCUMENTATION				
	Final Inspection Dossiers for submittal to Client upon completion of the job.	All documents as per approved ITP	ZS-Standard/As per the Final Dossier Index sheet	Final Inspection Dossier (FID)	S

Legend:

R = Review	W = Witness by Radom	NCR = Non Conformance Report	PL = Packing List
I = Inspection	M = Monitor	CAR = Corrective Action Report	IRC = Shipment Release Certificate
H = Hold	S = Submit	ZS = Zamil Steel	IC = Inspection Certificate
* = If any	V = Verify	T = Testing	RL = Release
A = Attend	TC = Test Certificate	MTC = Material Test Certificate	P.O = Purchase Order
			SD = Shop Drawing
			RFI = Request For Inspection

Note: 1. Inspection allotment would mean (%) percentage by number of Pcs to be Inspected.
2. Pre-Inspection Meeting: one time before commencement of the job

Zamil Steel Buildings Vietnam Co., Ltd

Seamless quality assurance

Inspection and Testing Plan (ITP) for SS-Structural Steel Jobs

Test #	Nature of Inspection / Test	Extend of Insp. by ZSV	Acceptance Norm	Record Format	Inspection ZSV
1	Quality Control System Implementation	100%	ZSV QSM	CAR # ZMF 11	R/V
1.1	WPS/ PQR/ WQTR/ WELD MAP/ NDT/ PAINTING				
1.1.1	Welding Procedure Specifications	100%	AWS D1.1:2015	WPS/PQR/NCR#ZMF 12*	V
1.1.2	Welders /Welding Operators Qualification Records.	100%	AWS D1.1:2015	WQTR/NCR#ZMF 12*	V
1.1.3	Weld map	100%	Shop Drawing	NCR # ZMF 12*	R
1.1.4	NTD Procedures/ NDT Technician certificates	100%	Procedures/Certificates	NCR # ZMF 12*	R
1.1.5	General Procedure for Surface Preparation & Coating	100%	Procedure/SSPC (SP1&2)	NCR # ZMF 12 *	R
2	* PRE-INSPECTION MEETING (If required - Note 2) (Before commencement of the job)	One time		MOM	A
3	MATERIAL RECEIPT INSPECTION		ASTM A572 Gr.345/SS400/ or Equivalents/P.O Material Spec/P.O	P.O	
3.1	Steel Plates/Shapes				
3.1.1	Verification of Purchase Order requirements	100%	Material Spec/P.O	Report # QCF 01	I
3.1.2	Mill Test Certificate review.	100%		NCR # ZMF 12*	R
3.2	Fasteners: Bolts/Nuts/Washer				
3.2.1	Verification of Purchase Order requirements	100%	ASTM/ANSI/DIN(931/933)/P.O	Report # QCF 01	I
3.2.2	TC & MTC review.	100%	ASTM/ANSI/DIN(931/933)/P.O	NCR # ZMF 12*	R
4	MATERIAL PREPARATION Shearing/ Gas Cutting, Machining, Sawing, Drilling or Punching, etc				
4.1	Visual Inspection	10% Min.	AISC-15th/SD	NCR # ZMF 12*	I
4.2	Dimensional Inspection	10% Min.	AISC-15th/SD	NCR # ZMF 12 *	I
5	FABRICATION AND FIT UP COMPONENTS				
5.1	Dimensional check of fit up components, holes, overall length, hard stamp markings (primary members)	75% Min.	AISC-15th/SD/QCP11R01	Insp. Rpt #QCF 20	I
5.2	Dimensional check of fit up components, holes, overall length, hard stamp markings (Secondary Members, Sundries Parts)	25% Min.	AISC-15th/SD/QCP11R01	Insp. Rpt #QCF 20	I
6	IN-PROCESS WELDING INSPECTION				
6.1	Welding consumable Receipt Inspection	100%	AWS D1.1:2015/P.O	NCR # ZMF 12*	I
6.2	Verification of actual Welding Parameters	10% Min	WPS/PQR	NCR # ZMF 12*	V
6.3	Verification of Welders Qualification	100%	WQTR	NCR # ZMF 12*	V

Zamil Steel Buildings Vietnam Co., Ltd

Seamless quality assurance

Test #	Nature of Inspection / Test	Extend of Insp. by ZSV	Acceptance Norm	Record Format	Inspection ZSV
7	NON-DESTRUCTIVE TESTING				
7.1.1	Visual Inspection (primary members)	75% Min.	AWS D1.1:2015	Insp. Rpt #QCF 23	I
7.1.2	Visual Inspection (secondary/sundry members).	10% Min.	AWS D1.1:2015	Insp. Rpt #QCF 23	I
7.2.1a	Primary Members butt welds - splice (Flange & Web) Thickness \geq 8 mm - UT	100%	AWS D1.1:2015	UT Rpt#QCF 06	T
7.2.2b	T & Corner CJP welds Thickness \geq 8 mm - UT	10% Min.	AWS D1.1:2015	UT Rpt#QCF 06	T
8	SURFACE PREPARATON & PAITNING				
8.1	Receipt Inspection of Abrasives, Paints, Thinner	On every P.O	P.O/Job Spec	Insp. Rpt #QCF 01	V
8.2	Surface Cleanliness-Shot blasting (SA 2 ½) or Job specs	10% Min.	SSPC/Job Spec	NCR # ZMF 12*	I
8.3	Anchor profile	10% Min.	SSPC/Job Spec	NCR # ZMF 12*	I
8.4	Mixing/Application/Recoat/WFT	10% Min.	SSPC/Job Spec	NCR # ZMF 12*	W
8.5	Visual inspection of Coating	50% Min.	SSPC/Job Spec	NCR # ZMF 12*	I
8.6	Paint – DFT – (Minimum Require't as specified)	25% Min.	SSPC-PA2/Job Spec	Insp. Rpt #QCF 24	I
8.7	Marking	5% Min.	SD/Job Spec	NCR # ZMF 12*	V
8.8	Touch up (Repair).	50% Min.	SSPC/Job Spec	NCR # ZMF 12*	W
9	GALVANIZING				
9.1	Zinc Quality & MTC Review.	100%	ASTM B6	NCR # ZMF 12*	V/R
9.2	Surface cleaning-SP8 (Acid picking)	5% Min	SSPC/Job Spec.	NCR # ZMF 12*	M
9.3	Visual Inspection of Zinc Coating	20% Min	SSPC/Job Spec.	NCR # ZMF 12*	V
9.4	Zinc coating thickness – (As per ASTM A123)	20% Min.	ATSM A123-17/ Job Spec.	Insp. Rpt.#QCF 18 Galvanizer/Certificate	I/H
9.5	Adhesion Test: (Hammer or Stout Knife Test)	5% Min.	ATSM A123-17/ Job Spec.	NCR # ZMF 12*	T
9.6	Repair Galvanizing or Touch up.	20% Min.	ATSM A123-17/ Job Spec.	NCR # ZMF 12*	W
10	INSPECTION RELEASE CERTIFICATE (IRC)				
10.1	Pre-Shipment Inspection (** RFI)	25% Min.	Job Specs.	#QCF 10	I
10.2	Packaging Inspection (Truck load)	25% Min.	Job Specs.	Packing List	I
11	DOCUMENTATION				
	Final Inspection Dossiers for submittal to Client upon competition of the job	All documents as per approved ITP	ZS-Standard/As per the Final Dossier Index sheet	Final Inspection Dossier (FID)	S

Legend: R = Review
I = Inspection
H = Hold
* = If any
A = Attend

W = Witness @ Random
M = Monitor
S = Submit
V = Verify
TC = Test Certificate

NCR = Non Conformance Report
CA = Corrective Action
ZS = Zamil Steel
T = Testing
MT = Material Test Certificate

PL = Packing List
SRC = Shipment Release Certificate
IC = Inspection Certificate
RL = Release
SD = Shop Drawing
RFI = Request For Inspection

Note: 1) Inspection allotment would mean (%) percentage by number of Pcs to be Inspected
2) Pre-Inspection Meeting one time before commencement of the job

Zamil Steel Buildings Vietnam Co., Ltd

Unparalleled services

Logistic

Inland and sea transport are two methods used for shipping our steel constructions.

When delivering buildings to locations within Vietnam and other countries that are easily accessible by trucks, inland transport is preferred.

Shipping of our building parts, carried in 40-foot containers, is conducted via sea transport, mainly for places outside Vietnam. Our products reach any part of the world with the ease of sea transport.

As sea shipments to overseas ports may risk damaging the goods during loading or unloading, breakbulk shipments are mostly avoided to prevent customer inconvenience.

Loading and unloading dry containers are usually tedious and time-consuming tasks. They are no longer an issue owing to the expertise of our logistic management officials, who efficiently handle the whole process in a much easier, quicker, more economical, and damage-free way.



Site Supervision

Zamil Steel Buildings Vietnam provides complete installation services for our steel constructions and structures. Our professional Erection Coordinators (EC) assigned for site supervision of clients' projects efficiently fulfill the tasks regardless of size and location.

Our ECs assist you in not just unloading the materials on-site but also supervising the entire planning and execution of procedures to guarantee that your building is established as per the agreement with Zamil Steel's international safety and quality standards.

Following are the standard procedures involved in our scope of work:

1. Receiving and analyzing engineering documents
2. Pre-erection checks
3. Container unloading and material delivery procedures at the site and checking materials' quality and quantity
4. Construction of steel buildings consistent with Zamil Steel's international safety and quality standards. The entire process follows our standard Erection Procedures
5. Inspection and testing program
6. Documentation, reports, and handing over to customers
7. Maintenance plan, if required.

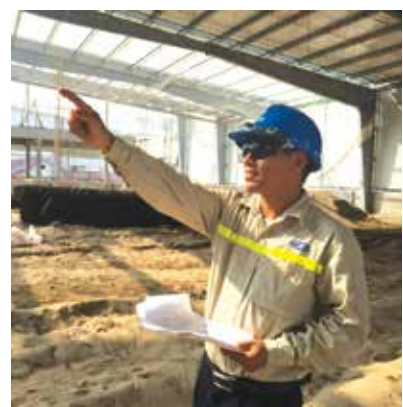

Zamil Steel Buildings Vietnam Co., Ltd

Unparalleled services

Quality control of erection works

The safety and quality of our construction work are warranted by our dedicated, experienced, and qualified engineers, supervisors, and technicians.

Quality control is conducted throughout the various stages of the assembly process, beginning with the receipt inspection until the building is eventually handed over. A standard ITP/quality plan or a project-specific ITP/quality plan is followed.

The quality plan should minimally comprise the following:

1. Inspection and Testing Program (ITP; Attachment I [2 pages])
2. Erection Inspection Checklist (EICL; Attachment II [3 pages])
3. Method Statement
4. Procedures and Inspection Forms referred to in the ITP (Erect.03.03.R1)
5. Bolt tightening procedure (Attachment III [3 pages])
6. Paint touch-up procedure (Erect.03.03.R1)
7. Site organization chart including a dedicated qualified person for QC and safety 34
8. Construction does not begin without:
 - The submission of the Quality Plan
 - Appointing a dedicated Quality and Safety Person
 - Conducting a pre-inspection meeting (PIM)

Environment, health and safety at work (EHS)

The environment, health, and safety at work are crucial to Zamil Steel Buildings Vietnam Co., Ltd.

We consider safe working places and high environmental standards to prevent hazards and injuries while simultaneously encouraging innovation and business opportunities.

We also believe that most incidents and accidents involving safety and the environment can be prevented, be it in our factories or at all our workstations, including construction job sites.

Our teams are dedicated to paying attention to their own safety while working at your job sites, while visiting them, or at your workplaces.

Our teams would also ensure that the sub-contractors, erectors, and builders designated by Zamil Steel for establishing your pre-engineered buildings (PEB) and steel structures will work as per the highest possible EHS standards.

We strive to achieve “zero incidents” at our own and our customers’ workplaces.

As steel is a recyclable material, we are dedicated to minimizing our production rejects to the maximum possible extent and to contributing towards recycling our waste as far as we can.





CHAPTER 2: THE PRODUCTS

Pre-engineered steel buildings

MaxSEAM[®] roof system

Structural steel



The Pre-Engineered Steel Building (PEB) System

Pre-engineered steel building systems (PEB) are customized steel buildings that are tailor-made to users' architectural and engineering requirements. Maximum cost-effectiveness is achieved by using built-up members that are tapered (varying the web depth) according to local loading effects, thereby saving the material in low-stress areas.

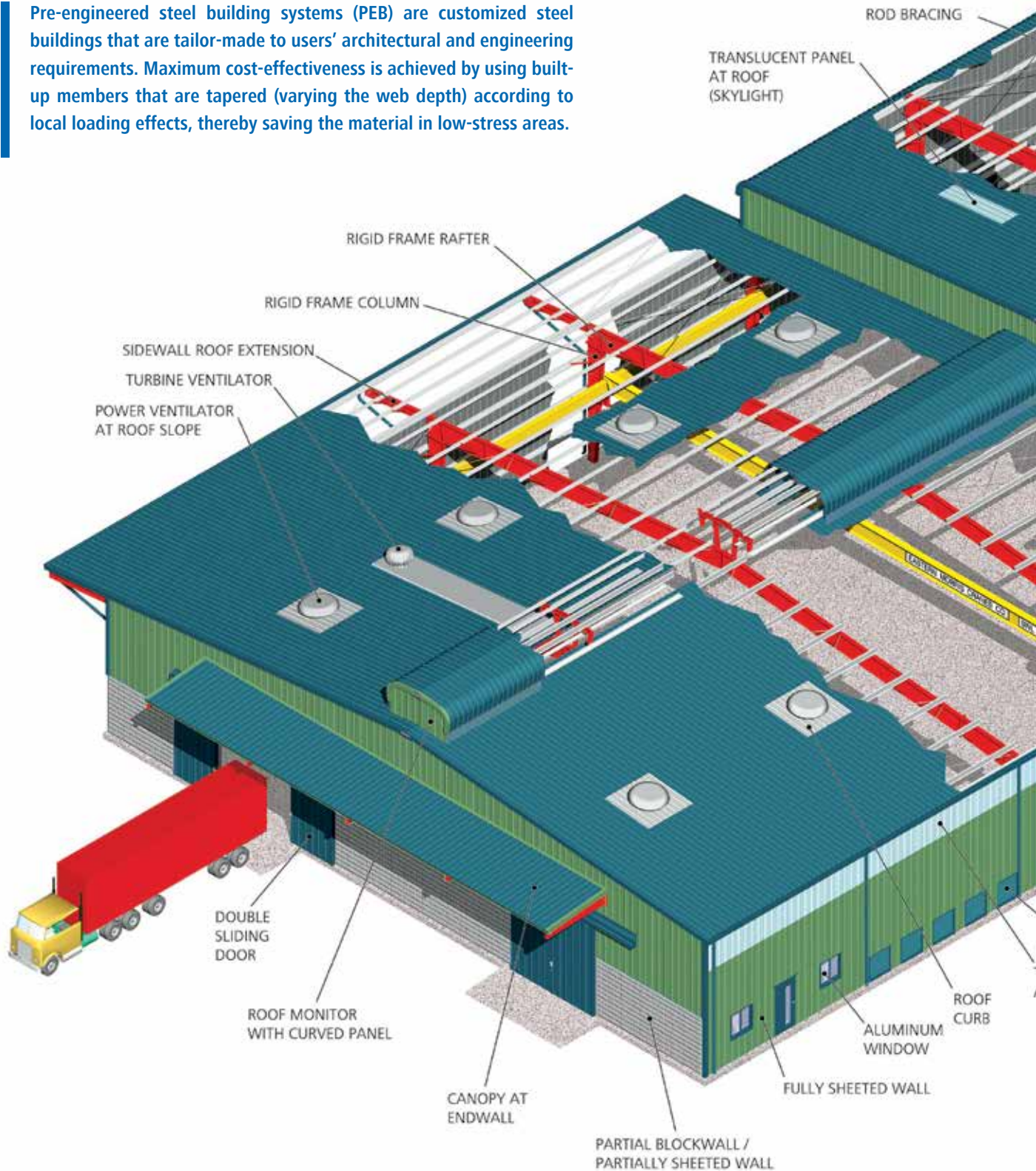

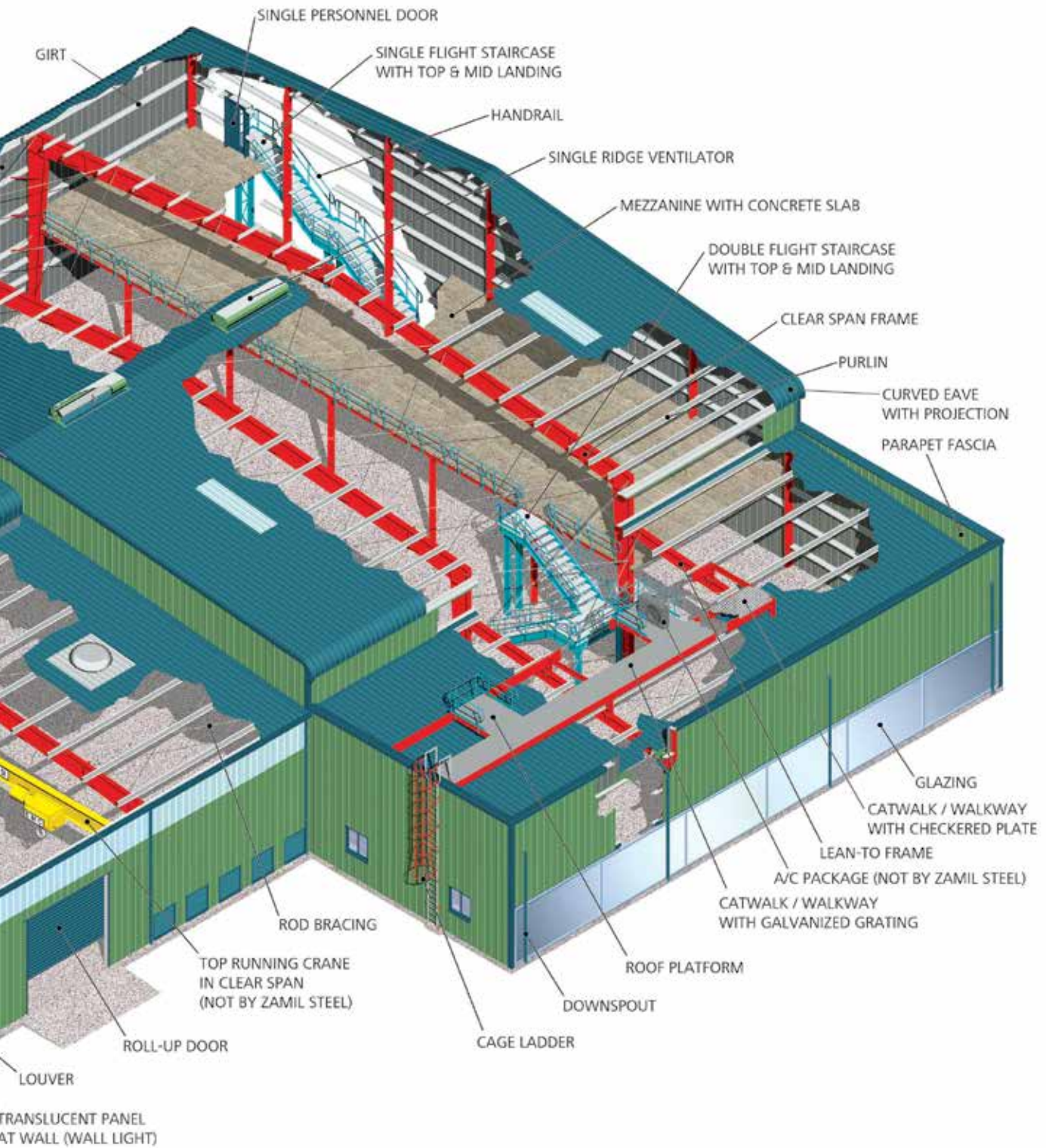

Basic Building Parameters

Zamil Steel's pre-engineered steel buildings are designed to meet clients' custom requirements. The basic parameters that define a pre-engineered steel building are as follows:

Building Width: No matter what primary framing system is used, the building width is defined as the distance from outside of eave strut of one sidewall to outside of eave strut of the opposite sidewall.

Building Length: The building length is the distance between the outside flanges of the endwall columns in opposite endwalls. Building length is a combination of several bay lengths.

End Bay Length: This is the distance from outside of the endwall columns' outer flange to the center line of the first interior frame columns.

Design parameters for roof live load, wind speed, snow loads, earthquake loads, collateral loads, or any other local climatic condition (if required) must be specified at the time of quotation.

Loads are applied in accordance with the latest American codes and standards applicable to pre-engineered steel buildings, unless otherwise requested at the time of quotation.

Interior Bay Length: This is the distance between the center lines of two adjacent interior main frame columns. The most common bay lengths are 6m, 7.5m and 9m. Any bay length up to 15m is possible.

Building Height: Building height is the **eave height** which usually is the distance from the bottom of the main frame column base plate to the top outer point of the eave strut. Eave heights up to 30 m are possible. When columns are recessed or elevated from finished floor, eave height is the distance from finished floor level to top of eave strut.

Roof Slope (x/10): This is the tangent of the roof with respect to the horizontal. The most common roof slopes are 0.5/10 and 1/10. Any practical roof slope is possible.

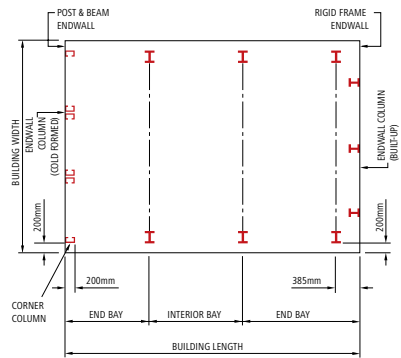

Building Length: Whenever possible maintain equal bay lengths throughout the building. When this is not possible, make all interior bays equal and make the end bays equal but shorter than the interior bays.

Example: A 100m long building will have 10 interior bays at 9m and 2 end bays at 5m or 11 interior bays at 8m and 2 end bays at 6m.

Building Width: Whenever possible make building width a multiple of 3 m. This is because roof purlins are spaced at 1.5 m and 3 m is equal to two purlin spacings one on each side of the ridge.

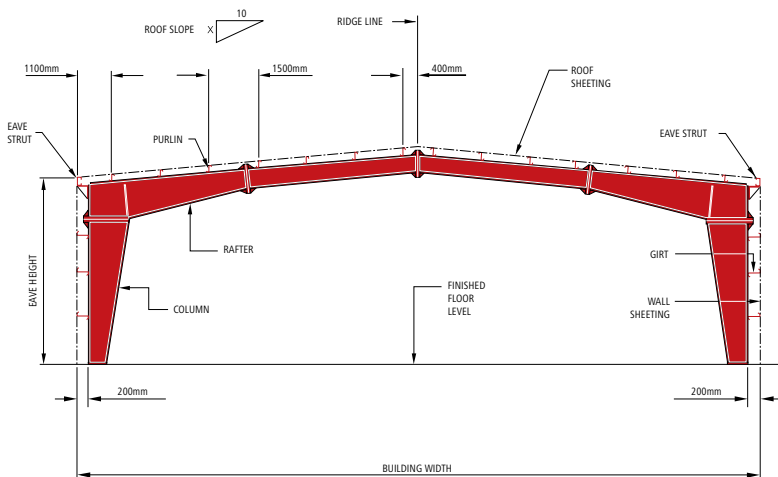

For more details, please refer to the drawings below for pre-engineered steel buildings

Primary Framing Systems

In conventional steel buildings, mill-produced hot rolled sections (beams and columns) are used. The size of each member is selected on the basis of its maximum internal stress. Since a hot rolled section has a constant depth, many parts of the member in areas of low internal stress are in excess of design requirements.

Frames of pre-engineered steel buildings are made from standard plates stocked by the manufacturers of the buildings. The pre-engineered steel building frames are normally tapered and have flanges and webs of variable thicknesses along the individual members.

The frame geometry matches the shape of the internal stress bending moment diagram, thus optimizing material usage and reducing the total weight of the structure.

The most common primary framing systems are shown below. Zamil Steel's engineering group will design the proper systems to fit with clients' requirements for building usages.

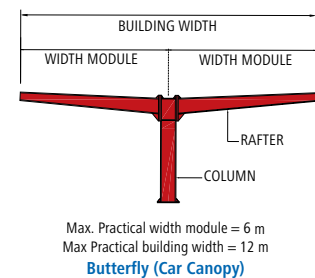
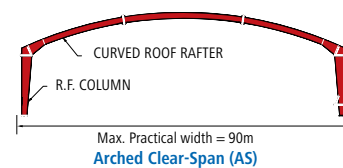
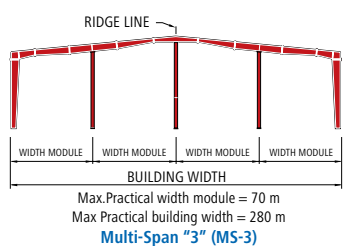
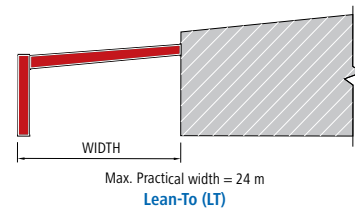
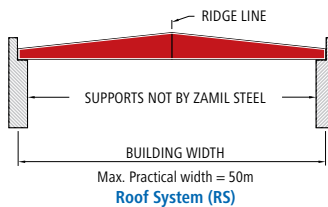
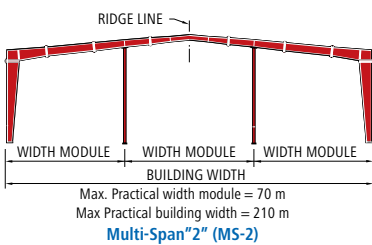
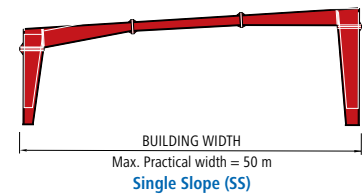
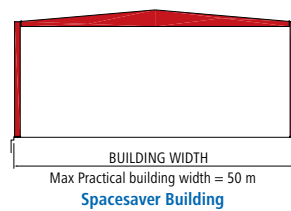
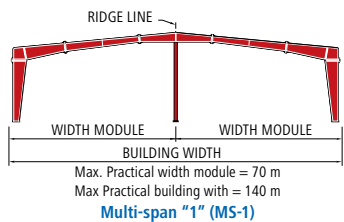
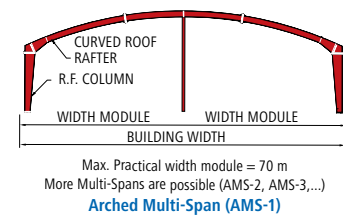
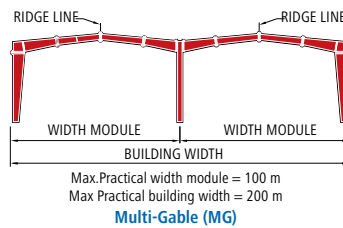
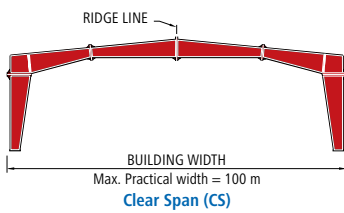

Pre-engineered Steel Buildings vs. Conventional Steel Buildings

	ZAMIL STEEL® PRE-ENGINEERED STEEL BUILDINGS	CONVENTIONAL STEEL BUILDINGS
STRUCTURE WEIGHT	<p>Pre-engineered steel buildings are 30% lighter. Primary framing members are tapered, built-up sections with large depths in the areas of highest stress.</p> <p>Secondary members are light gauge (lightweight) roll formed "Z" - or "C" - shaped members.</p>	<p>Primary steel members are selected from standard hot rolled "I" sections, which are (in many segments) heavier than required by the designs.</p> <p>Members have constant cross-sections regardless of the varying magnitude of the local internal stresses along the member length.</p> <p>Secondary members are selected from standard hot rolled "I" and "C" sections, which are heavier.</p>
DESIGN	<p>Designing is quick and convenient. Buildings are mainly formed by standard sections and connections, significantly reducing design time.</p> <p>Basic designs are based on international design standards and codes.</p> <p>Specialized design software and applications are used for optimizing material and drafting.</p> <p>Design, shop detail sketches and construction drawings/blueprints are provided. Approval drawings are prepared within two weeks.</p> <p>Zamil Steel has a library of various standard designs on-hand for faster and more efficient delivery of designs.</p>	<p>Each conventional steel structure is designed manually from scratch, with fewer supporting design software and applications.</p> <p>Substantial engineering and detailing works are required on every project.</p> <p>Extensive consultancy time is required for designing and drafting, coordination, and review.</p> <p>Each project is a separate case, so engineers need time to develop the design and details of the unique structure.</p> <p>More complicated design requires extensive design and drafting time.</p>
ARCHITECTURE	<p>Outstanding architectural designs can be achieved. Traditional walls and fascia materials such as concrete, masonry and wood can be utilized.</p>	<p>Special architectural designs and features must be customized if needed for each project, requiring research time and thus often resulting in much higher costs.</p>
DELIVERY	<p>Ranging from 6 to 8 weeks.</p>	<p>Ranging from 20 to 26 weeks.</p>
FOUNDATION	<p>Simple, lightweight and easy to construct.</p>	<p>Extensive, heavy foundation is required.</p>
CONSTRUCTION SIMPLICITY	<p>Standard connections among components make the learning curve steeper for construction of each subsequent project.</p> <p>Periodic job site support is provided.</p>	<p>Connections are complicated and differ from one project to another.</p>

Pre-engineered Steel Buildings vs. Conventional Steel Buildings

	ZAMIL STEEL® PRE-ENGINEERED STEEL BUILDINGS	CONVENTIONAL STEEL BUILDINGS
CONSTRUCTION COST AND TIME	<p>Construction cost and time are precisely calculated.</p> <p>Our pre-engineered steel buildings are erected by professional, experienced builders. They usually have stock of standard components on-hand, enabling them to complete the projects on time should any shortage of materials occur.</p> <p>The systematic construction procedures are easy and fast, and require hardly any complex equipment.</p>	<p>Conventional steel buildings are 20% more expensive than pre-engineered steel buildings. In most cases, construction cost and time cannot be estimated precisely.</p> <p>Extensive time and manpower are required for construction. Heavy machinery and equipment are often needed.</p>
SEISMIC RESISTANCE	The low-weight flexible frames offer greater resistance to seismic forces.	Rigid, heavy structures do not perform well in regions prone to earthquakes.
OVERALL PRICE	Price per square meter could be up to 30% lower than for conventional steel buildings.	The price per square meter is higher.
SOURCING & COORDINATION	Zamil Steel's pre-engineered steel buildings are supplied completely with cladding and all accessories. We also provide assembly service (if required by clients).	<p>Buildings and components are sourced from different suppliers.</p> <p>Coordination between suppliers and sub-contractors takes a considerable amount of time in project management.</p>
CHANGING AND EXPANSION	<p>Pre-engineered steel buildings manufacturers have raw materials in stock to easily accommodate order changes.</p> <p>Future changes and expansion are simple and easy, as project data and drawings are recorded for years in our system.</p>	<p>Substitution of hot rolled sections is expensive and time-consuming.</p> <p>Changes made to orders after hot rolled sections are shipped for fabrication often result in additional costs because the components cannot be reused.</p> <p>Project data is recorded separately by different parties, making it difficult to track.</p>
GLOBAL EXPERIENCE	Zamil Steel is a global supplier of pre-engineered buildings, with over 68,000 buildings supplied to 90 countries worldwide.	Conventional steel buildings suppliers are more locally oriented and have less experience.

Crane Systems

For buildings that require crane systems, Zamil Steel designs the supports base on crane capacity and operation detail.

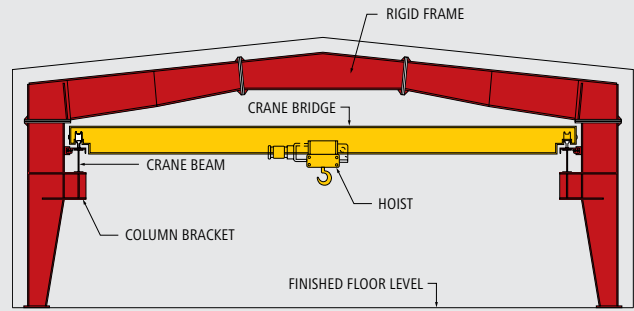

TOP RUNNING CRANE

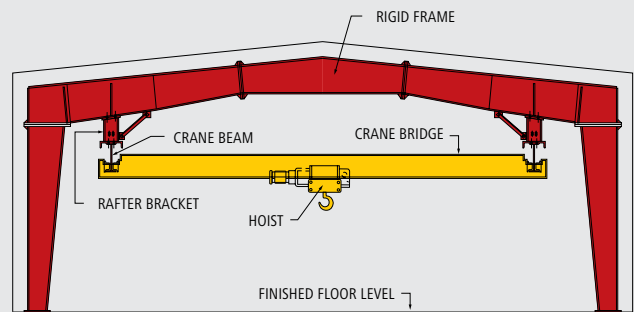

UNDERHUNG CRANE

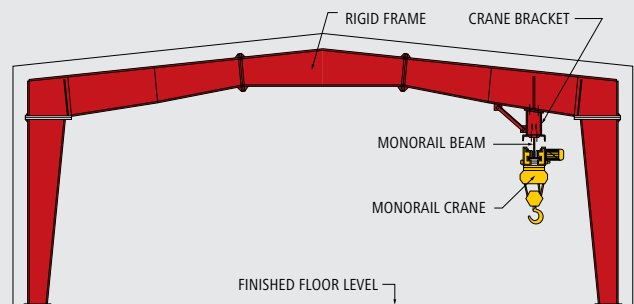

MONORAIL CRANE

Flooring Systems



Floor systems offered by Zamil Steel include flooring, catwalks, walkways, platforms, all their components and subsystems such as grating, checkered plates, staircase, handrails and guardrails.

Flooring system options range from single to multiple levels.

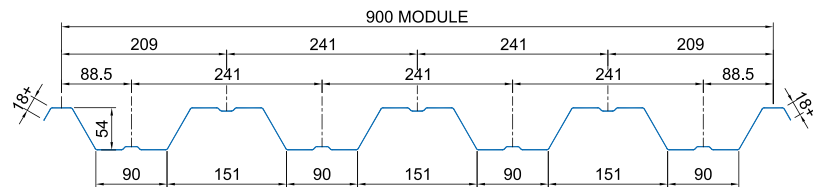

0.7MM THICK - TYPE "K" PROFILE PANEL
(For mezzanine decking)



Section Properties

Section Properties												
Nominal			Effective Top In Compression				Effective Bottom In Compression				Web Shear & Cripp	
Thickness mm	Weight kg/m ²	Area cm ²	I _x cm ⁴	Z _{x-Top} cm ³	Z _{x-Bott.} cm ³	Ma kN.m	I _x cm ⁴	Z _{x-Top} cm ³	Z _{x-Bott.} cm ³	Ma kN.m	V _a kN	P _a kN
0.70	7.29	9.47	40.34	12.92	15.26	2.67	41.35	15.10	13.59	2.81	24.20	13.07

Load Table [kN/m²]

Panel Thickness mm	Number of Spans	Load Case	Span in meters									
			1.00	1.25	1.45	1.70	1.90	2.15	2.35	2.60	2.80	3.00
0.70	1	D+L	12.80	10.24	8.83	7.11	5.09	3.52	2.69	1.99	1.59	1.29
		WP	12.80	10.24	8.83	7.39	5.91	4.62	3.87	2.98	2.39	1.94
		WS	8.41	6.73	5.80	4.95	4.43	3.91	3.58	3.06	2.45	1.99
	2	D+L	10.45	8.36	7.21	6.15	5.50	4.69	3.95	3.24	2.81	2.45
		WP	10.45	8.36	7.21	6.15	5.50	4.69	3.95	3.24	2.81	2.45
		WS	3.37	2.69	2.32	1.98	1.77	1.57	1.43	1.29	1.20	1.12
	3	D+L	11.89	9.51	8.20	6.99	6.26	5.53	4.87	3.75	3.00	2.44
		WP	11.89	9.51	8.20	6.99	6.26	5.53	4.87	4.01	3.48	3.04
		WS	3.83	3.06	2.64	2.25	2.02	1.78	1.63	1.47	1.37	1.28

Flooring Systems

1. Concrete floor

Reinforced concrete slab is cast on the metal deck (0.7mm thick) supplied by Zamil Steel.

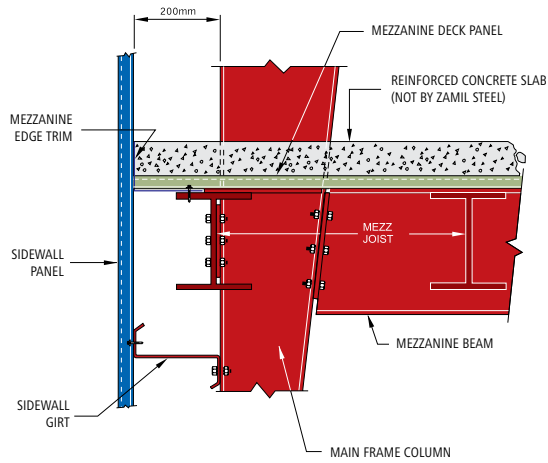

MEZZANINE BEAM CONNECTION TO MAIN FRAME COLUMN

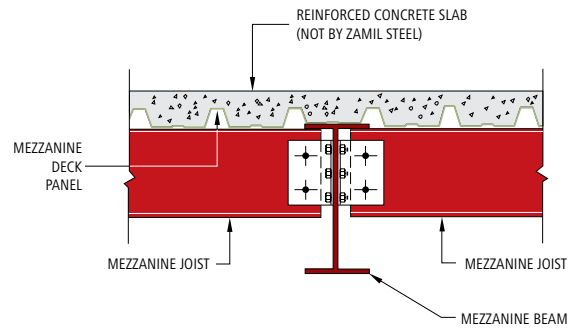

MEZZANINE JOIST CONNECTION TO MEZZANINE BEAM



NON-COMPOSITE DESIGN WITH STEEL DECK SUPPORT



COMPOSITE DESIGN WITH STEEL DECK AND SHEAR STUD

Flooring Systems

2. Galvanized steel grating floor

Grating is a kind of floor finishing that uses galvanized steel and is connected to the main frame by clamps.

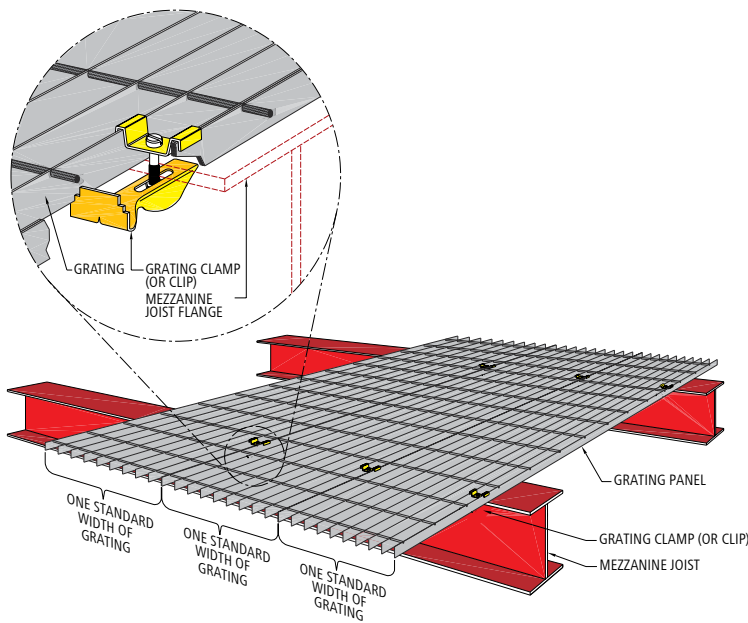

MEZZANINE GRATING CONNECTION TO JOIST

3. Checkered plate floor

The checkered plate is a floor finishing that connects to the main frame by fin neck bolts.

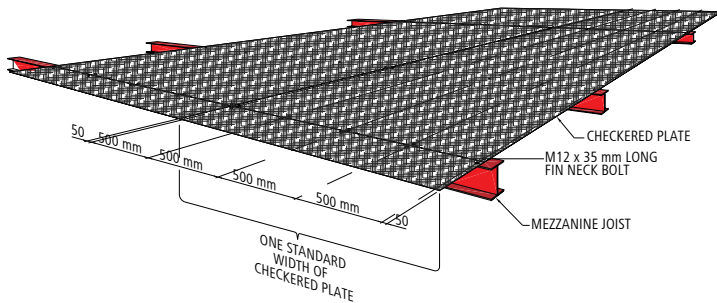

MEZZANINE CHECKERED PLATE CONNECTION TO JOIST

Sub - Flooring Systems

Catwalk, Walkway, Staircase, Handrail

Catwalk

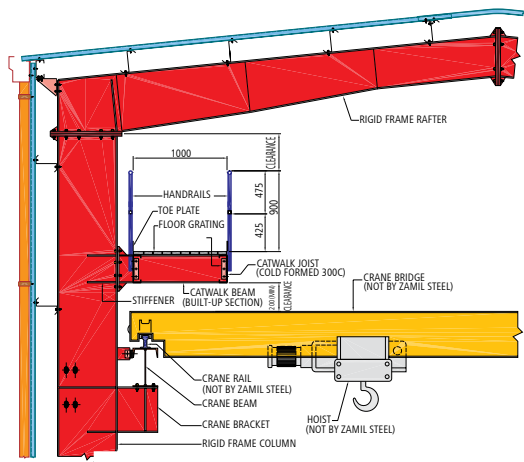

CATWALKS AT RIGID FRAME COLUMN

Walkway

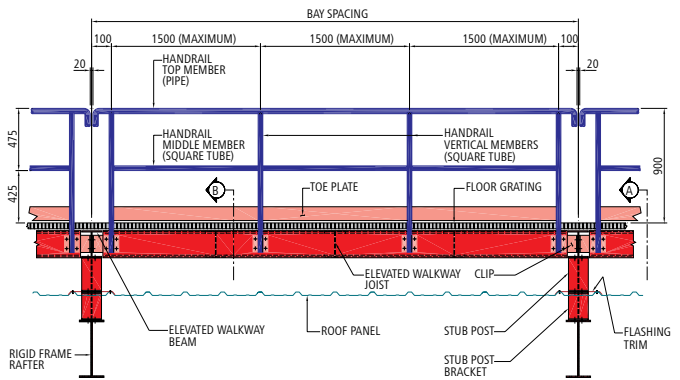

ELEVATED WALKWAY

Handrail

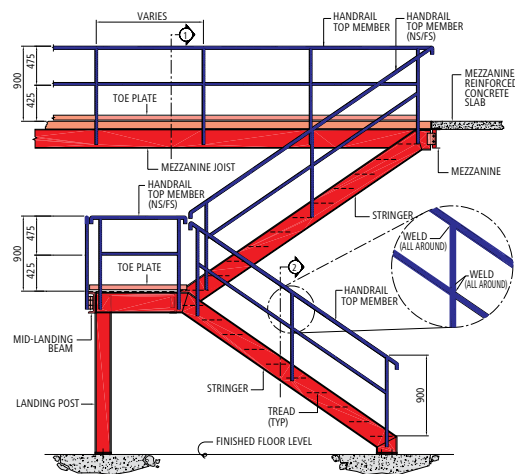

TYPICAL INDUSTRIAL HANDRAILS

Staircase

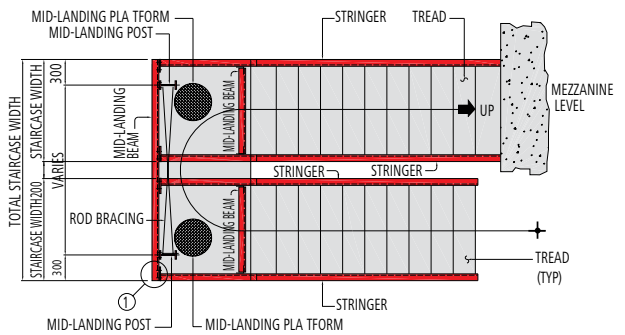

DOUBLE FLIGHT STAIRCASE

Sub-Structural Systems



ENDWALL ROOF EXTENSION



SIDEWALL ROOF EXTENSION

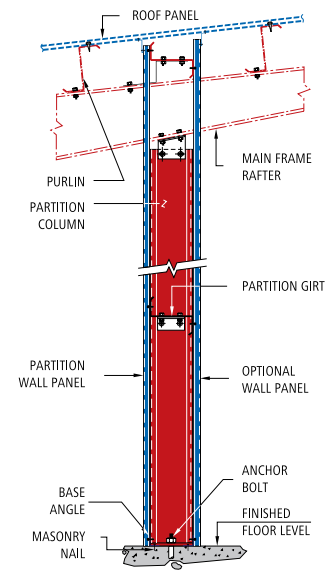
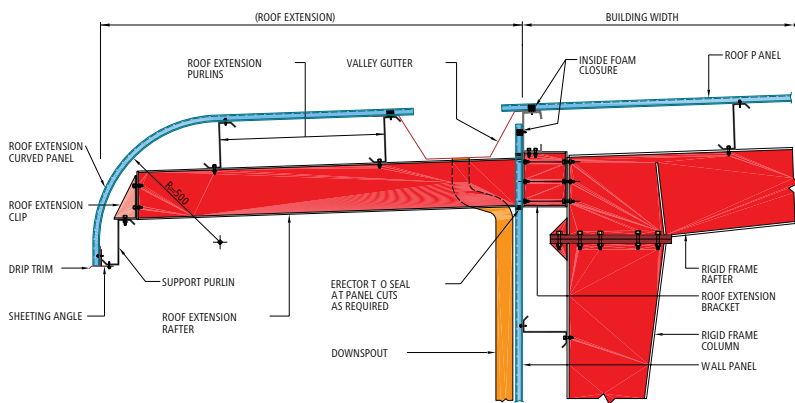
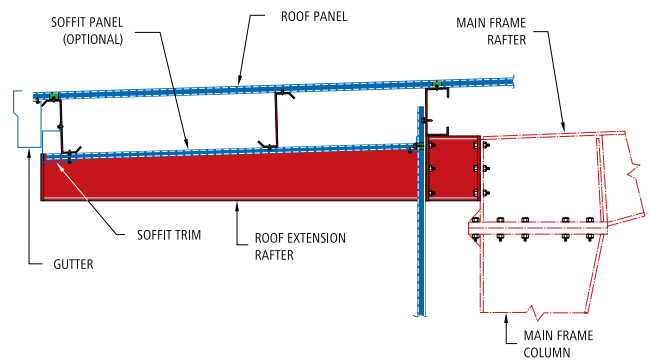
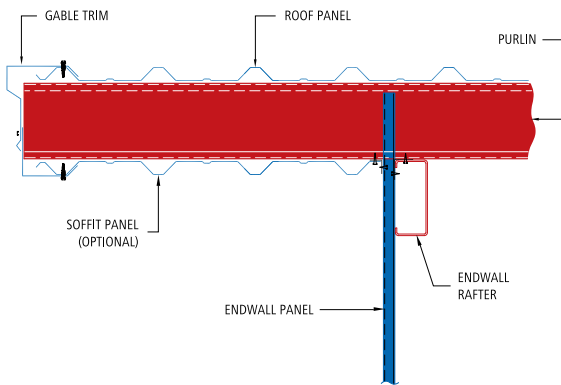

CURVED CANOPY

LONGITUDINAL PARTITION



Sub-Structural Systems



CURVED EAVE WITHOUT PROJECTION (WITH VALLEY GUTTER)



VERTICAL FASCIA WITH BACK UP PANEL AND VALLEY GUTTER

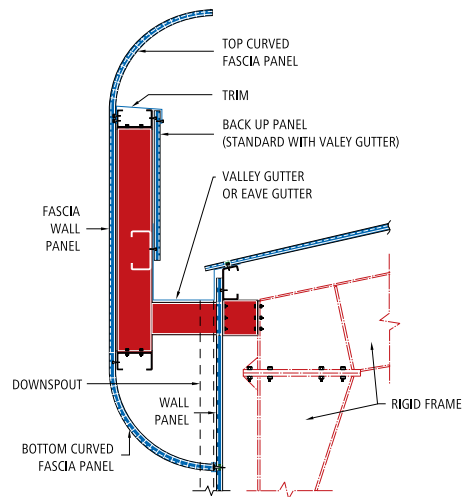
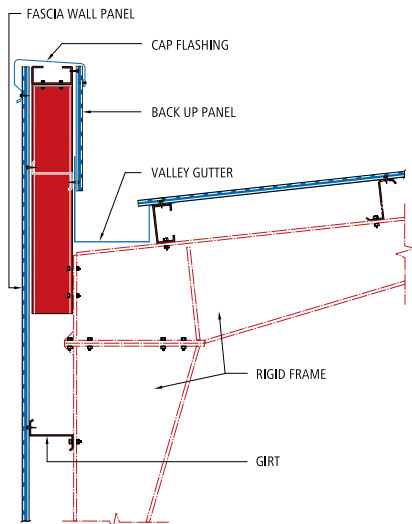
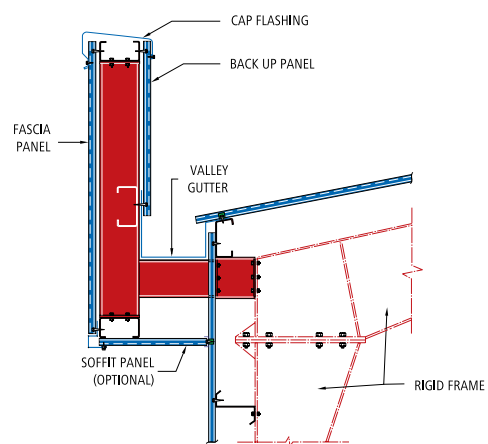
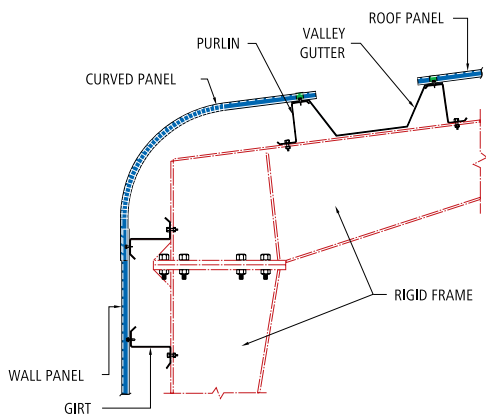

PARAPET FASCIA



TOP AND BOTTOM CURVED FASCIA PANEL



Secondary and Bracing systems

Secondary Framing System

"Z"-shaped roof purlins and wall girts are used for the secondary framing. They are lighter than the conventional hot rolled "I" - or "C"- shaped sections in conventional steel buildings.

Nesting of the "Z" - shaped members at the frames allows them to act as continuous members along the length of the building. This doubles the strength capacity of the "Z" - shaped members at the laps, where the maximum internal stresses normally occur.

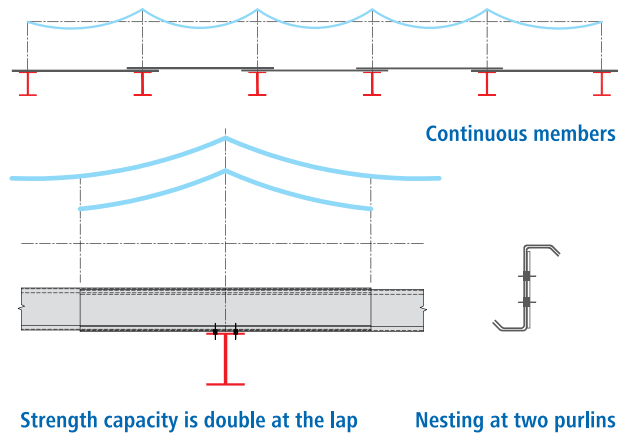

Secondary Members

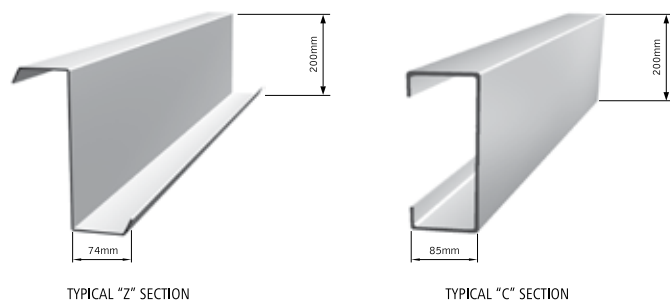

SECONDARY MEMBERS
(Minimum Yield Strength is 34.0 kN/cm²)

Cold-formed from steel coils (available in 1.5mm, 1.75mm, 2.0mm and 2.5mm thickness) conform to AS 1397 G450, Coating Z 275 (or its Equivalent) with zinc coating to Z275 designation (275 g/m²).

Bracing Systems

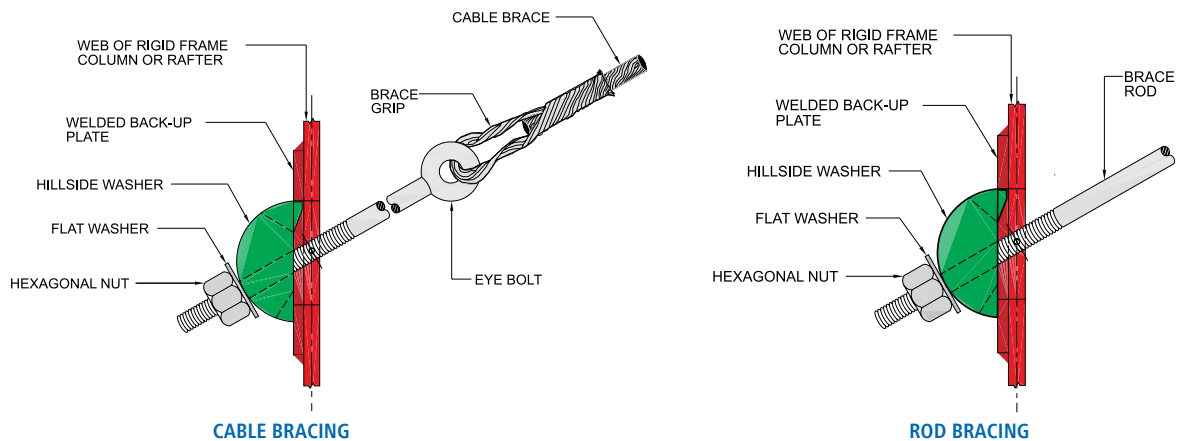

Bracing systems help to utilize materials and improve the flexibility of the designs. These systems are divided into 2 types:

- Bracing rod conform to JIS G3101 SS400 (or equivalent) with an ultimate tensile strength of 40.0 kN/cm²
- Bracing cable conform to ASTM A475-03, class A with minimum breaking strength is 119.657kN

Building Accessories

Doors and Windows

Based on your requirements, we supply all building accessories such as windows, louvers, sliding doors, roll-up doors, personnel doors, etc.



Aluminum Window ↑



Fixed Louver ↑



Personnel Door ↑



Double Sliding Door ↑



Roll-up Door ↑



Ridge Ventilator ↑



Translucent Panel (Skylight) ↑



Wall Light ↑



Insulation ↑

Examples of Sundry items



- Anchor Bolts
- Bolts and Nuts
- Mild Steel Bolt
- Hillside Washers
- Coupling Nuts
- Fasteners
- Sealants and Closures

Roofing, Wall Claddings and Drainage Systems

Wall cladding and Conventional roofing systems

Type S panel

The panels used for Zamil Steel pre-engineered steel buildings are composed of the following:

Base metal of Zamil Steel single-skin panels (minimum yield strength of 34.0 kN/cm²) coated with zinc (approximately 55%) and aluminum (45%), conforming to ASTM A792M-SS Grade 340 Class 2 (or equivalents).

An exterior surface or weather-facing coating on painted panels of 5 microns epoxy and 20 microns of high-durability polyester.

An interior surface coating on painted panels of 5 microns epoxy and 5 to 7 microns of regular polyester.

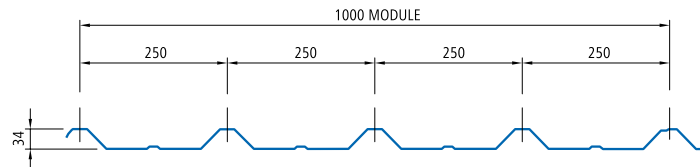

0.5MM THICK - TYPE "S" PROFILE PANEL
(For roof and wall application)

Standard Panel Colors

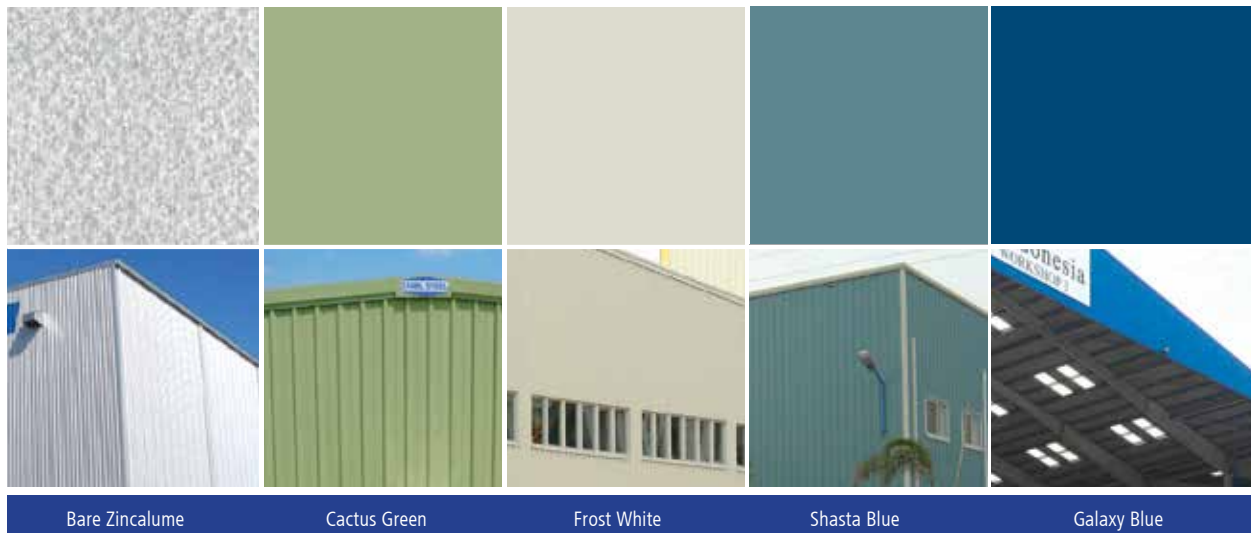

Bare Zinalume

Cactus Green

Frost White

Shasta Blue

Galaxy Blue

Actual color may differ slightly from printed examples. Refer to Zamil Steel's "Panel Chart (colors and profiles)" for actual color samples.

Bare Zinalume® steel panels (0.5mm nominal thickness) are available in all standard colors.

Panels may be specially ordered to any base metal specification, coating, finish, color and thickness. Consult Zamil Steel's representative for price and delivery.

* Other colors are available upon request (or shall be advised) in advance only.

Roofing, Wall Claddings and Drainage Systems

Trim

Trims are made of the same material as single-skin panels and are available in all standard panel colors. Shown below are the most common trims used in Zamil Steel pre-engineered steel buildings.

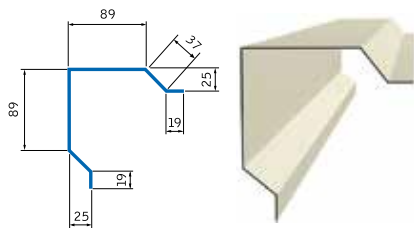

OUTSIDE CORNER TRIM
(at intersection of endwall and sidewall)

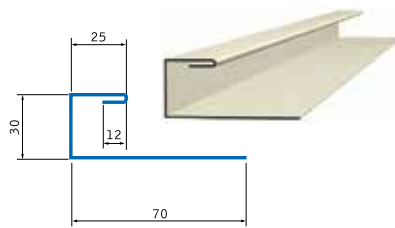

FRAMED OPENING TRIM

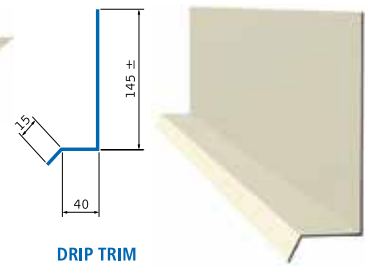

DRIP TRIM

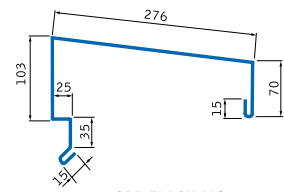

CAP FLASHING

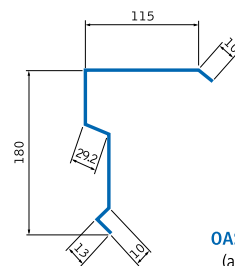

OASIS GABLE TRIM
(at endwalls only)

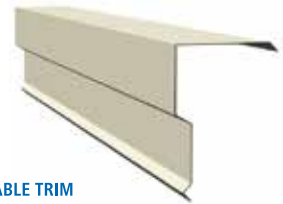

Drainage System

Eave gutters and downspouts are made of the same material as standard single-skin panels and are available in all standard panel colors. Valley gutters are made of plain Zinalume (1.0mm thick).

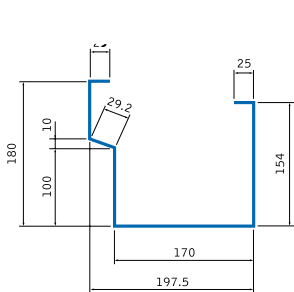

EAVE GUTTER

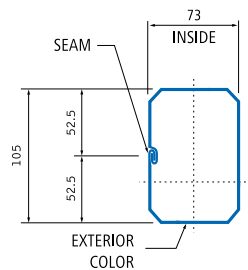

DOWNSPOUT

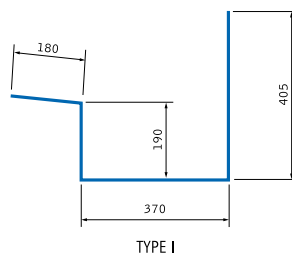

TYPE I

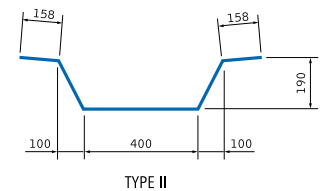

TYPE II



VALLEY GUTTER

Insulation

In roof installation, one of the challenging factors is thermal flows through unit area of a wall and roof system when temperature difference exists between airs on each side of the structure. To reduce heat gain or loss through the building envelope, Zamil Steel recommends that roofs and wall of pre-engineered steel buildings be insulated with Zamil Steel standard fiberglass insulation.

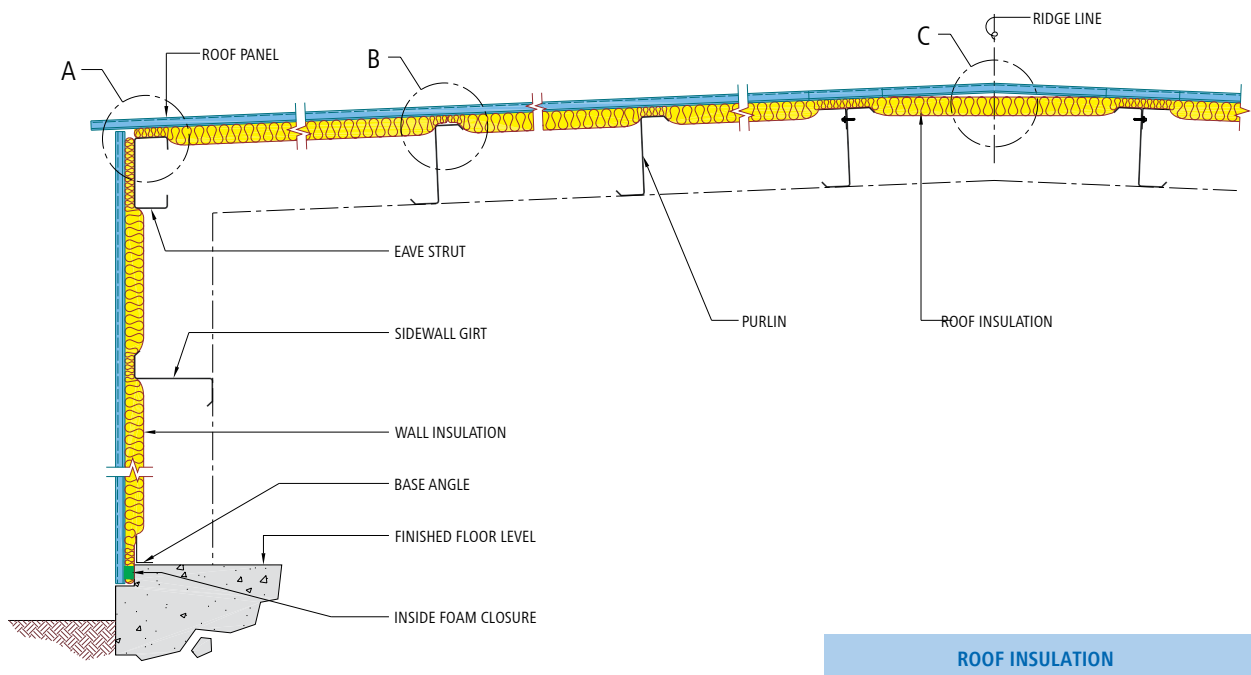

Features and Benefit Zamil Steel Standard Fiberglass Insulation

Zamil's standard insulation is, a highly efficient, lightweight, strong, resilient, and easy-to-handle flexible blanket fiberglass insulation. The insulation is composed of fine, stable, and uniformly textured inorganic glass fibers which is bonded together by a non-water soluble and fire-retardant thermosetting resin. Due to its mineral composition, the insulation is free from coarse fibers and shot particles.

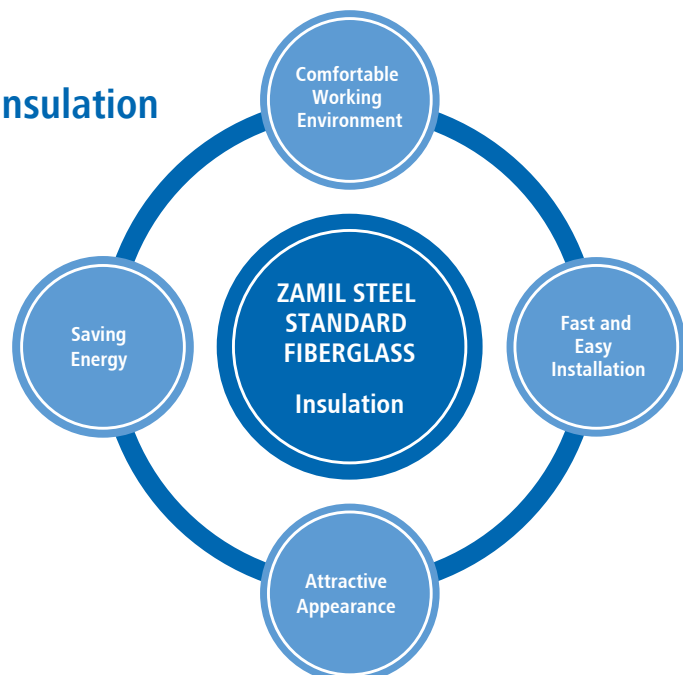

Insulation

Zamil Steel Standard Fiberglass Insulation

The main technical values of Zamil Steel insulation include the following:

Standard Nominal Density

10 - 12 kg/m³ - 0.625 - 0.75 lb/ft³

Working Temperature Limitations (ASTM C 411)

-4° to +260°C. At excessive temperatures and/or in contact with hot surfaces, a limited migration of binder may occur in the insulation. This in no way impairs the performance of the insulation.

Nominal Thermal Conductivity (ASTM C 518, B.S. 874)

"K" or "λ" = 0.040W/m. °C or 0.28Btu.in/ft².hr °F at 24°C or 75 °F mean temperature

Thermal Conductance, 'C' .Value (ASTM C 518,ASTM C 177)

C=1/R =W/m².OC or Btu/hr.ft².oF

Thermal Transmittance (U value)

Thermal transmittance is the rate of heat flow through unit area of a wall system when unit temperature difference exists between air on each side of the structure. The U value is the reciprocal of the sum of the resistances of the component parts of the structure plus the resistance of the surfaces and any cavities within the structure.



U=1/ Rt

U-values for roofs and walls using a 50mm and 100mm thick fiberglass with density 10kg/m³ are shown below:

Insulation Thickness (mm)	U value	
	Roof	Wall
	(W/m ² .K)	(W/m ² .K)
50	0.642	0.678
100	0.364	0.375

Thermal Resistance, "R" Value (ASTM C 167)

R-value is a measure of the resistance to heat of a material of any given thickness.

$$R = T/K$$

Where "T" = thickness and "K" or "λ" = thermal conductivity.

"R" = m².°C/W or hr.ft².°F/Btu.

Insulation

Zamil Steel Standard Fiberglass Insulation

R-Values of Standard Sizes Available

Insulation Thickness (mm)	R-value (m ² .K/W) at Various Densities			
	10 kg/m ³	12 kg/m ³	16 kg/m ³	20 kg/m ³
50	1.190	1.250	1.282	1.389
100	2.381	2.500	2.564	2.778

Sound Transmission

Sound transmission losses for single metallic wall sheet plus insulation (as per ASTM E90) are as follows:

Density Kg/m ³	Thickness (mm)	Sound Transmission Loss (dB)						
		Sound Frequencies (Hz)						
10	50	125	250	500	1000	2000	4000	STC
	10	12	14	15	21	21	25	20
12	50	11	15	16	29	31	37	24
	100	12	16	18	31	32	39	25
		11	17	21	34	35	42	27

Specifications and Material Characteristics of Zamil Steel Standard Fiberglass Insulation

Zamil Steel standard fiberglass insulation is manufactured by AFICO under license from and utilizing the manufacturing specifications and technology of **Owens-Corning Corporation**, Toledo, Ohio, U.S.A.

Specifications Compliance

Zamil standard fiberglass insulation complies with the property requirements of the following specifications

- U.S. Federal Specification HH-I-521 F,
- U.S. Federal Specification HH-I-558 B, TYPE I,
- CLASS 6, B-I
- TIMA Standard 202
- ASTM C 423

Insulation

Zamil Steel Standard Fiberglass Insulation

Fire and Safety Properties

- BS 476 Part 4: Non-combustible; ASTM E84 (Via UL 723); ASTM E136
- BS 476 Part 5: Ignitability
- BS 476 Part 6: Fire propagation
- BS 476 Part 7: Surface spread of flame
- UL 723, ASTM E 84, ASTM E 136: Surface burning characteristics

Base glass fiber is non-combustible when tested to ASTM E 84.

FACING	FLAME SPREAD	SMOKE DEVELOPED	FUEL CONTRIBUTED
FRK	25	10	0
WMS	20	30	0

Material Characteristics

- **Mold growth (ASTM D2020, UL181, ASTM C991)**

Non-Toxic, rot proof, odorless, non-hygroscopic and does not breed or sustain mold, fungus, bacteria or rodents.

- **Corrosiveness (ASTM C665)**

This non-corrosive and chemical insert will not cause or accelerate corrosion of steel, stainless steel, copper or aluminum, due to its inorganic and mineral composition.

- **Moisture absorption (ASTM D-07B, ATSM C553)**

In conditions of 95% relative humidity at 49oC for 96 hours, moisture absorption is less than 0.2% by volume, when tested in accordance with ASTM C553. Zamil Steel standard fiberglass insulation products do not absorb moisture from the ambient air nor water by capillary attraction.

- **Alkalinity**

PH9

- **Vapor permeability comply with ASTM E96 A 0.02**

Performance Characteristics

- **Compressive Strength**

PCF AT 10% DEFORMATION 5

PCF AT 25% DEFORMATION 10

- **Puncture resistance (ASTM D781)**

FRK 25 Units

WMSK 25 Units

Insulation

Zamil Steel Standard Fiberglass Insulation Facing

Zamil Steel standard fiberglass insulation is designed and factory-laminated to a choice of functional finishes in order to provide attractive interiors, resist abuse, and help control moisture or vapor condensation. Available standard insulation options include one-side factory-applied Foil Reinforced Kraft (FRK), White Metalized Scrim Kraft (WMSK) or other specific vapor barrier facings.

The proper facing preserves the inherent fire safety of metal buildings. These facings brighten the building interiors due to their high light reflectance, reduce the cost of interior lighting, and contribute to an effective vapor barrier to control condensation and dripping moisture.

Facing is 50mm wider than insulation in order to staple.

Type	Thickness (mm)	Light reflectance	Perm Rating
FRK	50	89%	0.02
WMSK	100	80%	0.02

Maintenance

No maintenance is required. Zamil Steel standard fiberglass insulation has a high resistance to accidental damage from knocks and handling during installation and maintenance. The insulation is dimensionally stable under varying conditions of temperature and humidity. It is also rot-proof, odorless and non-hygroscopic, and will not sustain vermin or fungus due to its inorganic and mineral composition.

Zamil Steel standard fiberglass insulation will maintain its thermal properties throughout the lifetime of the construction and will not age. It is also non-toxic and not hazardous to health.

Storage

To avoid introducing moisture to the building during construction, Zamil Steel standard fiberglass insulation must be kept in a dry place when stored outside.

Ventilator Systems

Zamil Steel Buildings Vietnam provides natural ventilator systems for steel buildings, with great ventilation capacity and excellent water leakage prevention.

A ventilator controls the interior environment of the building through reduction and removal of head build-up, gaseous byproducts, and flammable fumes, thus providing a healthier, more comfortable atmosphere for workers, preserving goods and enabling equipment to function properly, and minimizing fire hazards.

Ventilator systems come in two categories: inlet and outlet equipment. The principle of ventilation is shown as below.

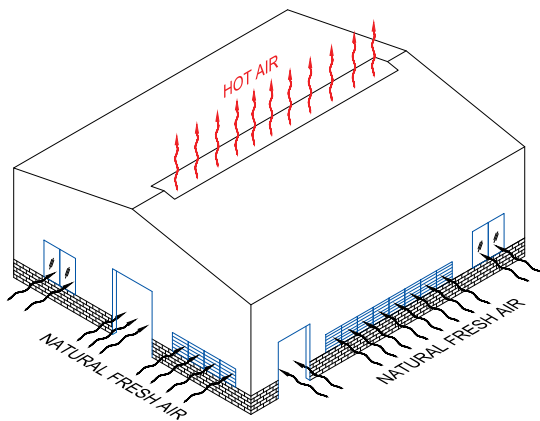

NATURAL VENTILATOR PRINCIPLE

Natural fresh air will enter the building through the inlet equipment, and hot air inside the building will go out through the outlet equipment.

Standard outlet ventilator

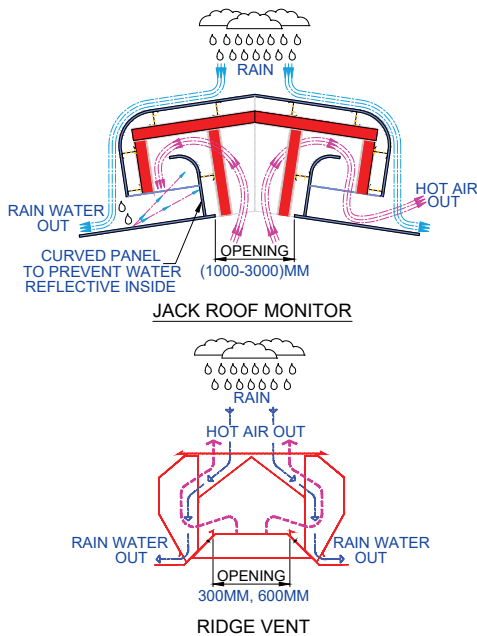

Zamil Steel Standard Outlet Ventilator Product

Standard inlet ventilator

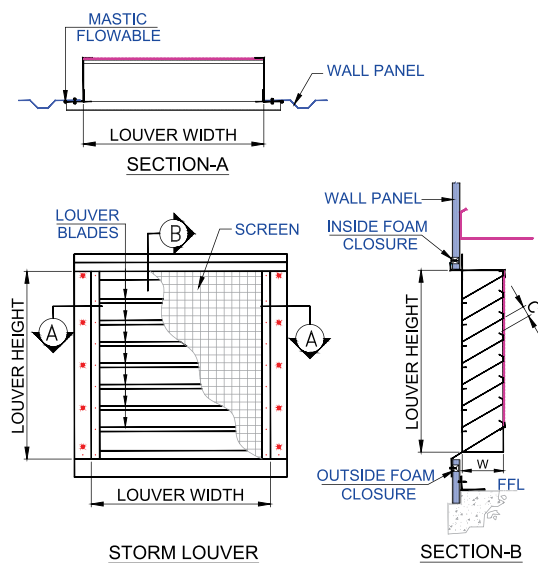

Zamil Steel Standard Inlet Ventilator Product

Examples of Pre-Engineered Steel Buildings Applications

Petrochemical	Automotive	Garment, Textile
Electronics	Food	Beverage
Paper	Plastic	Aviation
Ports	Hypermarkets, Shopping Malls	Apartments, Office Buildings
Agriculture	Schools, Universities	Sport Centers, Sport Halls



MaxSEAM®



The ultimate weatherproof roof system

The application of Standing Seam Roof systems (SSRs) have been one of the most exciting breakthroughs in roofing technology in the last 30 years. For the past few years, they have been widely used in almost 50% of all low-rise commercial, industrial and institutional buildings across United States, Europe and other regions. SSRs have also proven to be the most efficient, effective and value-for-money roofing systems for construction in rainy, windy and tropical regions.

The Zamil Steel MaxSEAM® roof system is one of the strongest and most weather-tight standing seam roof systems available in the industry today.



Features

The product features a 360-degree seam along the side laps of the panels; a special type of sliding clip and a carefully engineered system for improving strength, durability and resistance to weather.

The MaxSEAM® roof system acts as a monolithic membrane that completely protects your building, and is the most recommended roof system for tropical, rainy, snowy or high wind (cyclonic) regions.

Zamil Steel's MaxSEAM® can withstand up to 280km/h windspeed and higher windspeed value can be supported also by using special design.

Using Zamil Steel's Super SEAMER machine, the side laps of adjacent panels are seamed together, creating a 360 degree. double-lock seam, which has machine-applied mastic to ensure a secure, weather tight leak-proof joint. To increase weather-tightness level of this roofing system, the end laps could be eliminated by rolling MaxSEAM® panels on site, using a mobile roll former.

With our mobile roll former, the standard MaxSEAM® panels have a maximum length of 11.5 meters when they are roll formed in-house, while they can reach a length up to 100 meters when rolled on site.





MaxSEAM®

The ultimate weatherproof roof system

Benefits

- Weather-tightness**

MaxSEAM® assures adequate drainage from rain and snow. Designed as a water barrier, the raised seam assists drainage, while the end laps, inside closure, outside closure, tri-bead mastic, along with the machine-applied sealant (inside the seams), increase the lap tightness further.

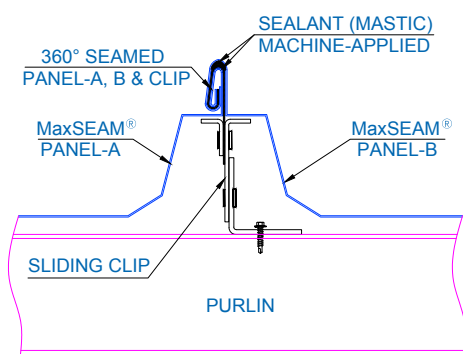

360° SEAMED WITH CLIP

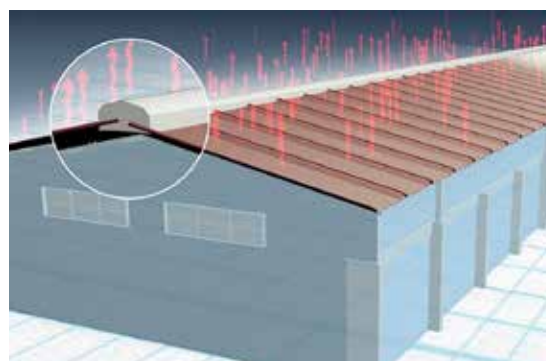

- Thermal Movement & Leakage Prevention**

The fastening system of MaxSEAM® is designed to handle the potentially damaging effects of thermal movement (especially heat expansion).

The system features a sliding clip which slides between the base components and intermediate components to eliminate binding and offers greater flexibility for durability and thermal movement, while also minimizing the probability of leakage.

Unlike most other SSR systems, the gables at both ends of the roof finish with a 76 mm high standing seam, instead of finishing in the low, flat part of the panel, where the greatest possibilities for leaks occurs.

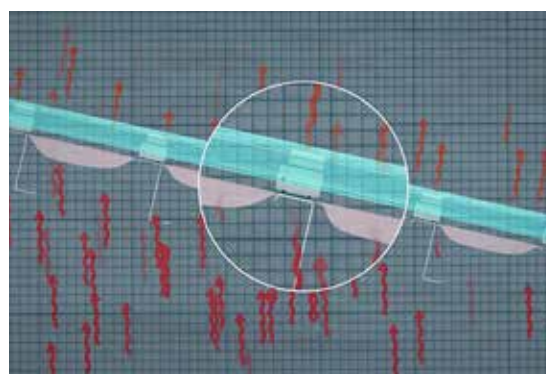

- Cost Effectiveness**

The life cycle cost of the MaxSEAM® roof system is lower than any other steel panel roof system. Using Zinalume coated steel, its life expectancy is longer since less maintenance is required.

MaxSEAM®



The ultimate weatherproof roof system

Quality Tests

• Uplift ratings

Carries UL90 Uplift ratings and covers a wide range of installation procedures, MaxSEAM® has met all test requirements as specified in CECS 07416 Standing Seam Metal Roofing System Guide Spec.

• FM Global Approved

Tested under ASTM E1646 "Standard Test Method for Water Penetration through Exterior Metal Roof Panel System" and ASTM E1680 "Test Method for Rate of Air Leakage through Exterior Metal Roof Panel System", MaxSEAM® has achieved FM Global's Approval as a Class 1 Roof Panel.

Under the same certification, MaxSEAM® also meets Class 1-SH hail damage requirements and 'Class 1A Fire Classification when installed at a maximum roof slope of 5 in 12 (42%).

• High-Quality Materials

MaxSEAM® panels are available in 0.5 mm - 18" panel width Zinalume coated steel. The Panels conform to ASTM A729M Grade 345B and are coated with a protective layer of Zinalume (55% aluminum, 1.6% silicon and 43.4% Zinc) alloy coating (150g/m² on both sides).

The steel panels are available in 0.53 mm (nominal) bare Zinalume or 0.56 mm (nominal) – 24" panel width, exterior roofing and walling (XRW) pre-painted Zinalume. Please refer to Zamil Steel sales representatives for availability of non-standard colors and non-standard coating systems (Exterior Premium Durability - XPD or Polyvinyl Fluoride-PVF2). We can provide you different options for:

1. Sketch of panels
2. Physical properties
3. Load tables
4. Material specifications





MaxSEAM®

The ultimate weatherproof roof system

Convenient Installation

MaxSEAM® roof system is installed using MaxSEAM® Mobile Roll Former and SuperSEAMER machine.

Using the Zamil Steel SuperSEAMER, the side laps of adjacent panels are seamed together through a mechanical action, creating a 360 deg. double lock seam, which has a machine applied mastic to ensure a secure and weather tight leak proof roofing system.

After pre-seaming the start of the panels using a Seaming hand tool, the SuperSEAMER is then fitted on to the pre-seamed panel, adjusted and locked, before the rollers are activated to start the complete electric seaming process. With the simple and quick release handle, it only requires a very short time to move the SuperSEAMER from one seam to another. Weather-tight 360 deg. seams are made without affecting the panel paint finish.



The MaxSEAM® mobile roll former will be used in case end laps are not preferred in the roofing system. The roll former machine weighs approximately 3.5 MT and can be transported to most jobsite via a container. With a roll forming capacity of between 12-15 m per minute, MaxSEAM® panels can be roll formed on site as a continuous panels for up to 100 m. Depending on the project size and requirements, Zamil Steel will consult with you for onsite-roll-forming of panels with length exceeding 50 meters.



Zamil Steel has appointed Authorized Installers of MaxSEAM® (AIM's) are assigned by Zamil Steel after having been adequately trained and experienced and possess the necessary facilities for installing MaxSEAM®. Zamil Steel strongly recommends that all MaxSEAM® roof systems should be installed only by one of our AIM's.

MaxSEAM®



The ultimate weatherproof roof system

MaxSEAM® CLIPS

• Fixed Clip

Zamil Steel's **MaxSEAM®** distinguishes itself from the many types of standing seam roof systems available in the industry. The strong **MaxSEAM®** clip is made from high-grade steel and has a long, sliding steel tab, which will be seamed with the **MaxSEAM®** panel.

Fixed clip is also available for the fixed side of the roof system and/or subject to guideline requirements.

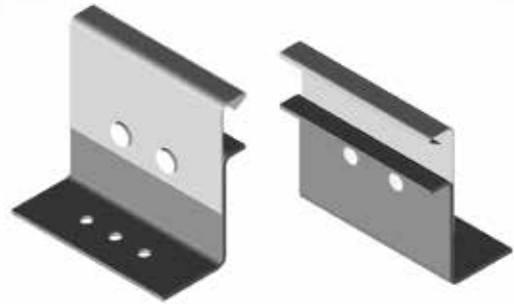

FIXED CLIP

• Sliding Clip

The sliding clip consists of a single component steel base that interlocks with two components in the sliding steel tab. The tab is attached to the base with two rivets and slides along a slot in the clip base.

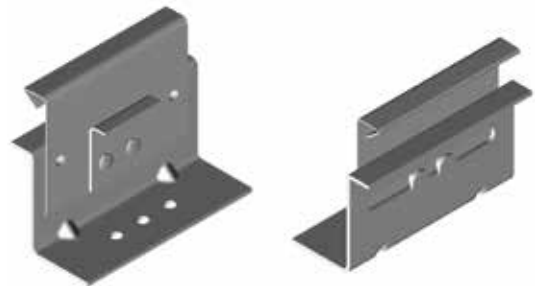

SLIDING CLIP

• Artifloat Clip

The ArtiFloat clip comprises of three main components; the base, intermediate component and sliding steel tab. ArtiFloat clip articulates and slides at the same time.

The ArtiFloat clip articulates between the base component and intermediate component of the clip thus eliminating binding.



ARTIFLOAT CLIP



MaxSEAM®

The ultimate weatherproof roof system

MaxSEAM® PANEL

• Specifications and Properties

MaxSEAM® panels conform to ASTM A792M SS Grade 340 Class 2 (or equivalent) and are coated with a protective layer of Zinalume (AZM 150). The MaxSEAM® steel panels are available with 18 inches, (457.2mm) wide profiles. The panels, at 18 inches (457.2mm) wide, are available in 0.50mm-thick (nominal) bare Zinalume or 0.53mm-thick (nominal) ZSP pre-painted Zinalume.

Please refer to Zamil Steel representative for extended deliveries on non-standard colors; non-standard coating systems (ZPF or PVF2) or non-standard thickness or 24 inch (609.6mm) MaxSEAM® panel.



• Section Properties

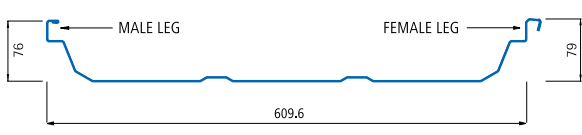

MaxSEAM® panel Cross – 24inch (609.6mm)

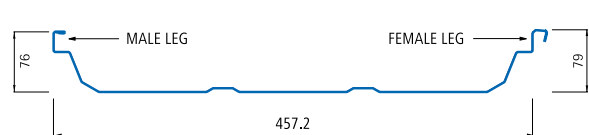

MaxSEAM® panel Cross – 18inch (457.2mm)

Section Properties

Panel Type	Panel Nominal Metal Thickness (mm)	FY (kN/cm ²)	Nominal Weight (kg/m ²)	Top in Compression			Bottom in Compression		
				Ix (cm ⁴)	Sx (cm ³)	Ma (kN.m)	Ix (cm ⁴)	Sx (cm ³)	Ma (kN.m)
18 inch wide	0.50	34.0	4.40	5.942	1.227	0.253	2.129	0.746	0.154
24 inch wide	0.53	34.0	5.12	4.009	0.815	0.168	1.786	0.635	0.131

All properties are per one foot (0.3048m) of panel width.

MaxSEAM[®]



The ultimate weatherproof roof system

MaxSEAM[®] PANEL

• Allowable Uniform Loads (kN/m²)

Notes:

- Allowable loads are based in uniform span length and $F_y = 34.0 \text{ kN/cm}^2$
- Wind load is allowable wind load and has been increased by 33.33%
- Deflection loads are limited by the maximum deflection of $L/240$ or maximum bending stress from live load.
- Weight of panel has not been deducted from allowable loads
- Load table values do not include web crippling requirements

Allowable Uniform Loads (kN/m ²)										
Panel Type	Panel Nominal Metal Thickness (mm)	Number of Spans	Load Type	Span (m)						
				0.91	1.07	1.22	1.37	1.52	1.68	1.83
18 inch wide	0.50	1	L.L Deflection	7.96	5.84	4.49	3.56	2.88	2.37	2.03
			WP	10.64	7.79	5.97	4.70	3.81	3.18	2.67
		2	L.L Deflection	4.86	3.58	2.47	2.17	1.72	1.46	1.19
			WP	6.44	4.72	3.62	2.87	2.34	1.90	1.64
		3	L.L Deflection	6.04	4.46	3.40	2.69	2.16	1.83	1.38
			WP	8.08	5.87	4.55	3.58	2.92	2.38	2.04
24 inch wide	0.53	1	L.L Deflection	5.29	3.87	2.96	2.34	1.88	1.58	1.32
			WP	7.03	5.19	3.97	3.15	2.54	2.09	1.78
		2	L.L Deflection	4.10	3.00	2.30	1.85	1.50	1.20	1.05
			WP	5.49	4.04	3.10	2.45	2.00	1.65	1.35
		3	L.L Deflection	5.15	3.79	2.90	2.30	1.58	1.54	1.19
			WP	6.85	5.04	3.85	3.05	2.45	2.05	1.70



MaxSEAM®

The ultimate weatherproof roof system

MaxSEAM® system details

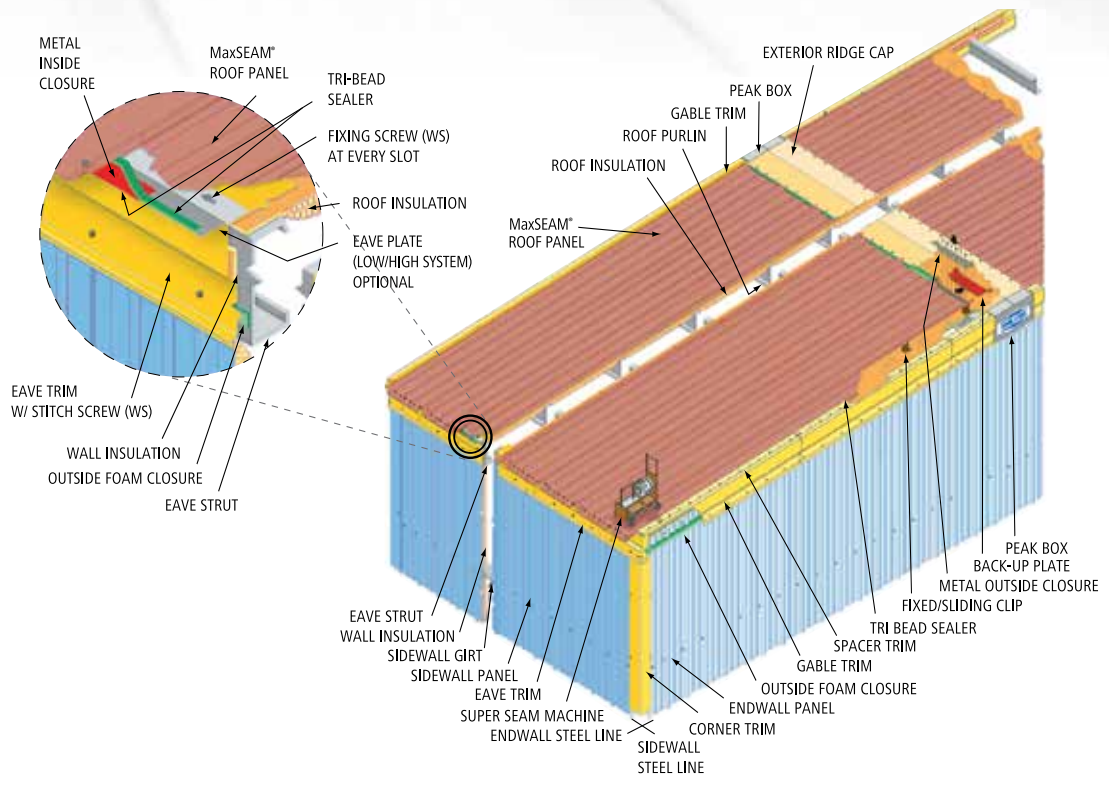

MaxSEAM® Accessories

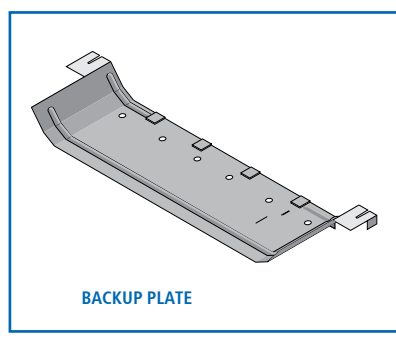
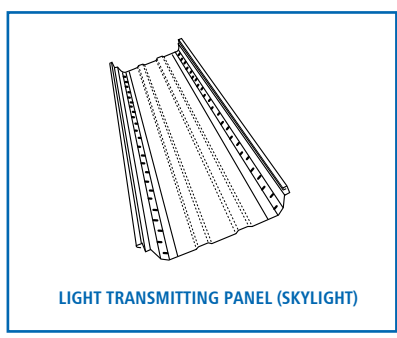
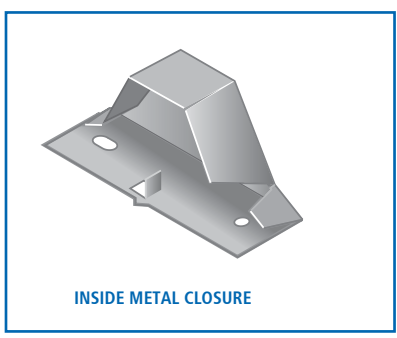
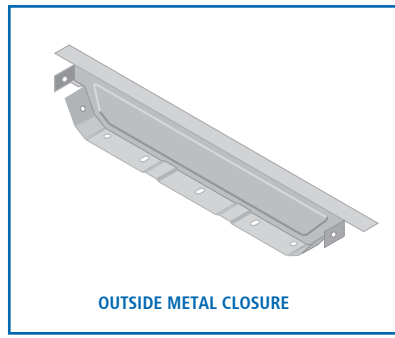
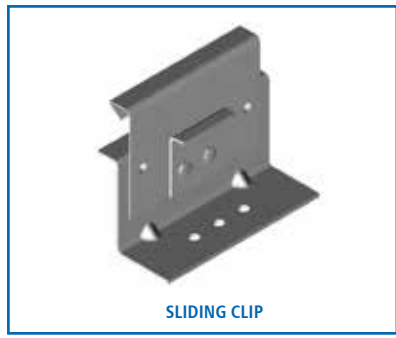

MaxSEAM®



The ultimate weatherproof roof system

Details at gable with insulation

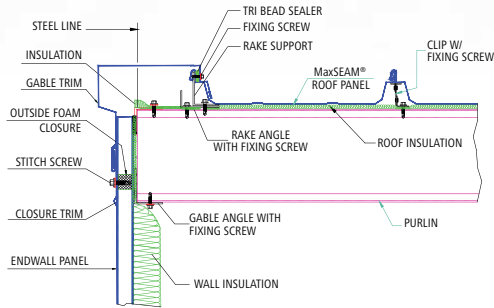

Details at ridge with insulation (floating)

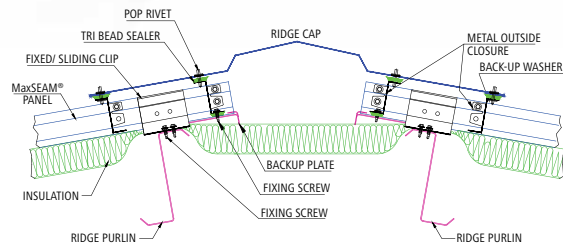

Roof monitor cross section with curved eave

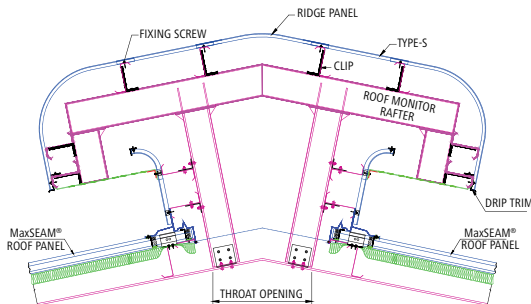

Skylight details for MaxSEAM® roof panel with insulation

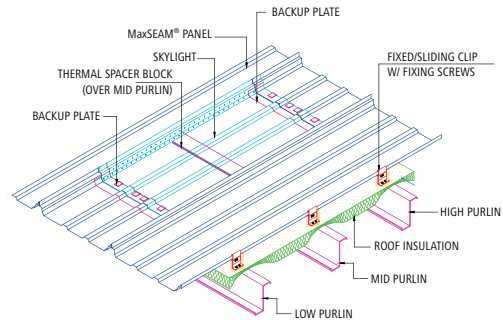

Detail of special eave gutter (fixed) with insulation

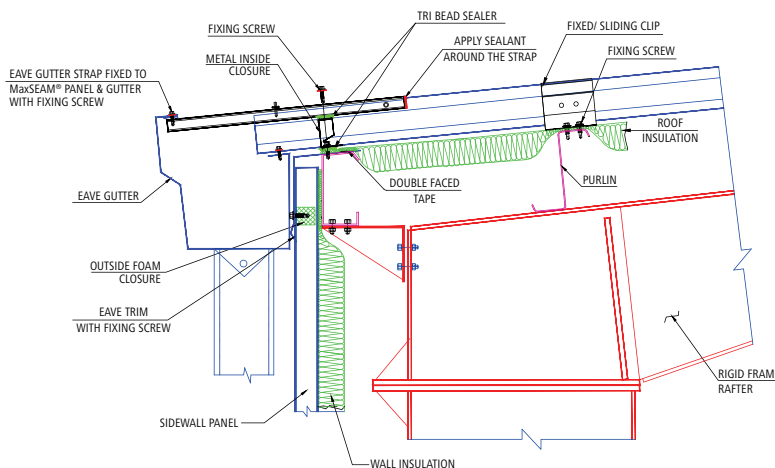

MaxSEAM®



The ultimate weatherproof roof system

Re-roofing system by MaxSEAM® panel

Depending on the level of maintenance, it is not uncommon for steel building roofs to deteriorate over the years, thus causing significant leakage problems. Solutions for this deterioration vary from partial replacement to replacement of the whole system, depending on your budget.

Roof cladding is the very first form of protection from external factors for your well-invested building structure and its contents. If your building was erected a long time ago, we recommend a checkup survey of your roofing system.

Delaying the inevitable will lead to further deterioration and possible consequential damage. For peace of mind in the years to come, our roofing experts provide ingenious, cost-effective MaxSEAM® re-roofing solutions without the unnecessary miscellaneous costs.

ADVANTAGE OF MaxSEAM® Re-roofing System

- **No Tear-off**

Thanks to its extremely lightweight features, MaxSEAM® roofing system can be installed right over the existing roof, thus eliminating the costly and time-consuming tear-off process.

- **Minimum Downtime**

With no need to tear off the existing roof, the re-roofing operation is minimized, hence reducing downtime. Furthermore, with zero exposure involved, the threat of damage to the building's interior and machinery is also significantly minimized.

- **Desirable Slope-to-drain**

Re-roofing with MaxSEAM® system can improve the roof gradient necessary for drainage. Moreover, MaxSEAM® re-roofing provides a low-slope solution to existing flat, built-up roofs. Introduction of slope to the flat roof allows re-routing of drainage to eliminate troublesome internal drains - saving time and money.

MaxSEAM® Re-roofing System

For supreme weather-tightness and long-term performance, customers can opt for re-roofing of the entire building with our MaxSEAM® panels. This solution allows for the installation of our MaxSEAM® system over an existing roof.

MaxSEAM® monolithic roofing possesses unique features to assure adequate drainage from rain, and is designed to handle the damaging effect of thermal movement by giving the entire roof a "floating" action.

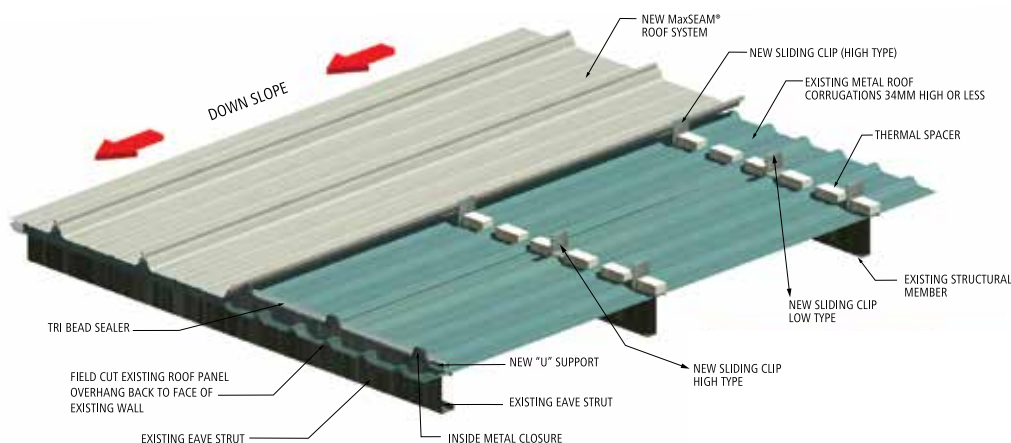

MaxSEAM®



The ultimate weatherproof roof system

• Installation of MaxSEAM®

MaxSEAM® roof system is installed on site using a field seamer - the SuperSEAMER Machine

After pre-seaming of the start of the panels using a Seaming hand tool, the SuperSEAMER is then fitted on to the pre-seamed panel, adjusted and locked, before the rollers are activated to start the complete electric seaming process. With the simple quick release handle, a very short time is required to move the SuperSEAMER from one seam to another. Weathertight 360 deg. seams are made without affecting the panel paint finish.



• SuperSEAMER

Using the Zamil Steel SuperSEAMER machine, the side laps of adjacent panels are seamed together through a mechanical action, creating a 360 deg. double lock seam, which has a machine applied sealant to ensure a secure and weather tight leak proof roof system.



• Mobile Roll Former

The MaxSEAM® mobile roll former is available if endlaps are not preferred in the roofing system. The roll former weighs approximately 3.5 MT and can be transported to most jobsite via a container. With a roll forming capacity of between 12 – 15m per minute, MaxSEAM® panels can be roll formed on site as a continuous panel for up to 90m.



MaxSEAM® Erection Procedures

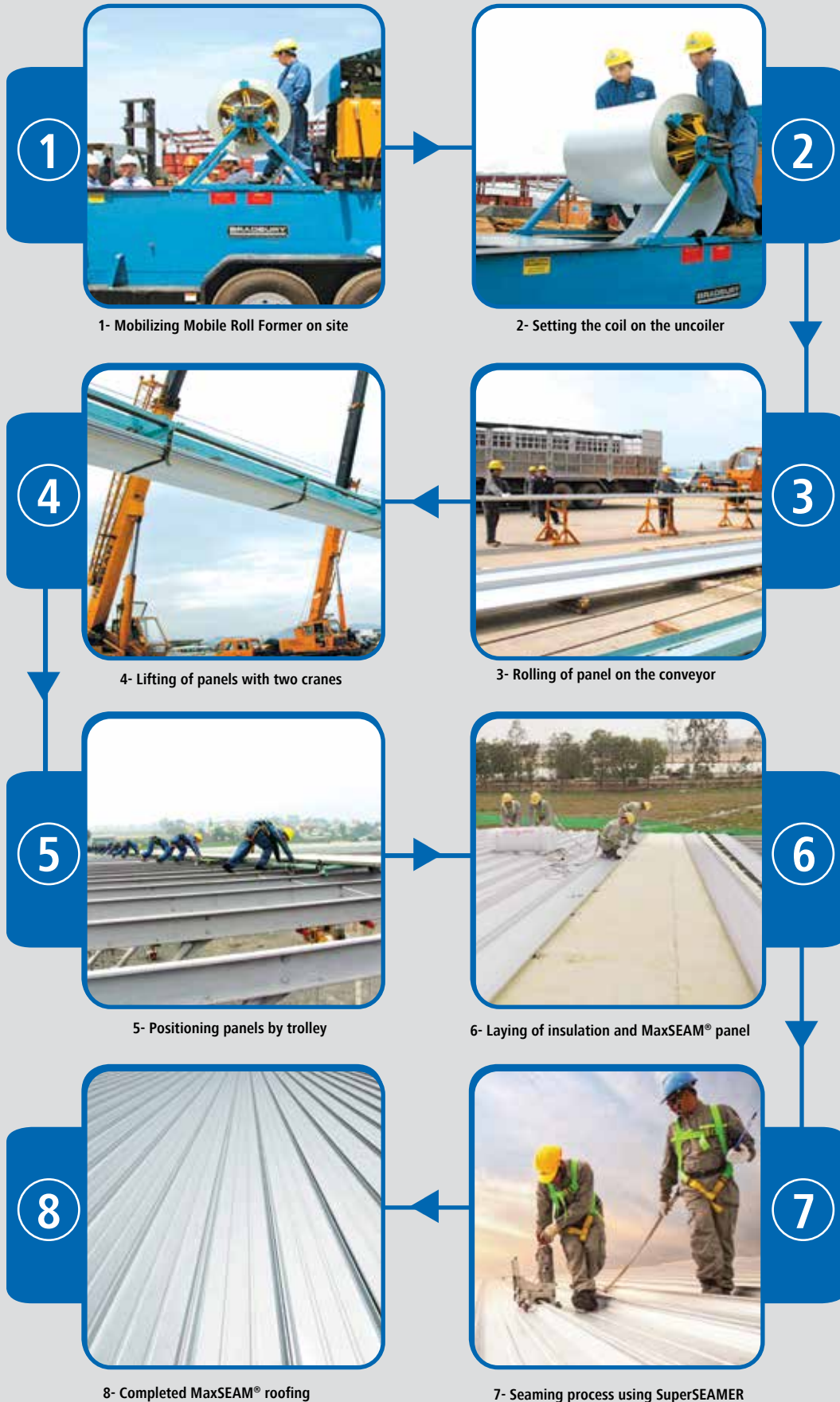

Structural Steel

Beside pre-engineered steel buildings, structural steel is another solution that Zamil Steel offers to clients with diverse requirements for large-scale and complex projects.

Our structural steel fabrication process is controlled by state-of-the-art computer numerically controlled (CNC) machines and equipment, utilizing the latest engineering software for detailing and connection design.

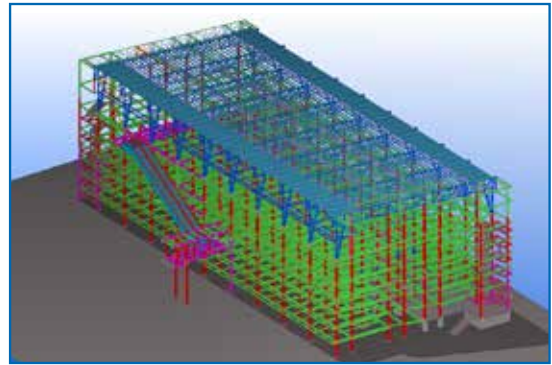

Zamil Steel's Strength on Structural Steel

• Sales and Marketing

Zamil Steel's structural steel products are backed by a skilled and experienced sales team that is highly talented, dedicated and objective oriented. With customer satisfaction as their top priority, the sales staff identify the customer's needs and requirements and respond professionally and promptly.

• Estimating

Short turnover and practical conceptual estimating strategy.

After receiving a new request for quotation along with the customer's BOQ, drawings and other relevant documents from our sales office, the estimating team conducts an initial conceptualization on a per-project basis, immediately raising relevant concerns and addressing clarifications.

Once all relevant information is provided and clarifications are addressed by the customer, an estimating engineer will proceed with the pricing stage and the preparation of a proposal offer. A series of reviews is set up to make sure that all assumptions and deviations are considered and that the price is reasonable and satisfactory to the customer.

We focus on our vision: to be the **provider of the market's most competitive and precise structural steel prices in this region while achieving total customer satisfaction.**

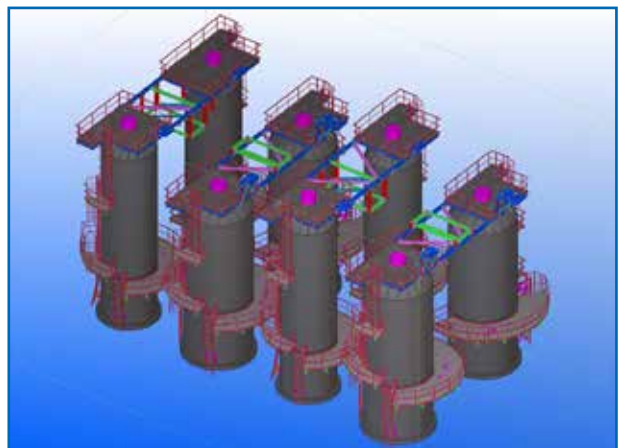
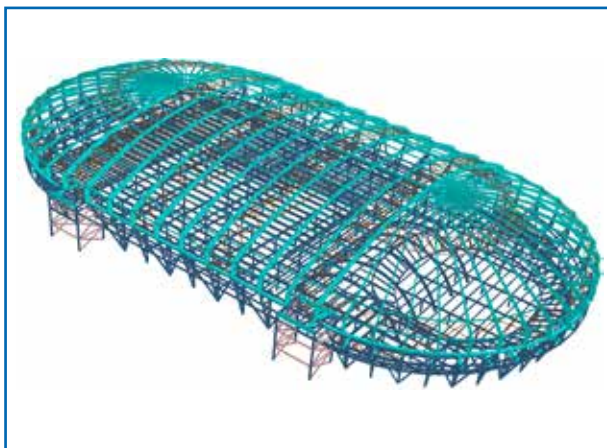



Structural Steel

• Engineering

Strong technical and expertise

Zamil Steel serves clients in various engineering and contracting sectors and offers professional expertise that covers all stages of design, from concept to completion, with due consideration of budget and time limitations.

The experienced and professional engineers of Zamil Steel utilize the latest software for detailing and connection design.

• Project Management

Systematic and skillful

Zamil Steel has a project management team of experienced engineers and skillful professionals dedicated to planning and managing all product- and service-related activities throughout the project life cycle.

• Fabrication

State-of-the-art technology

Zamil Steel continuously strives to find the latest methods, technologies, and machines to ensure the highest levels of productivity, quality and timely delivery for all our clients' satisfaction.

With more than 50,000m² of manufacturing facilities, Zamil Steel Buildings Vietnam delivers products of the highest quality and precision by combining up-to-date engineering software with comprehensive, modern production equipment.

• Seamless Quality Assurance and Control

A highly qualified and equipped internal quality control department ensures all Zamil Steel products are manufactured in accordance with stringent international standards. All inspection activities are carried out by certified professional engineers.

• Site Support Supervision Services

As part of Zamil Steel's long-term strategy to provide proper support and services to our customers before and after a sale, the project management department ensures that all our customers are satisfied with our services and solutions, from the date of placing the order with us until the building construction is completed.

We want to ensure that each building is erected in accordance with Zamil Steel's construction drawings/ blueprints, and following the proper and safe construction procedures.

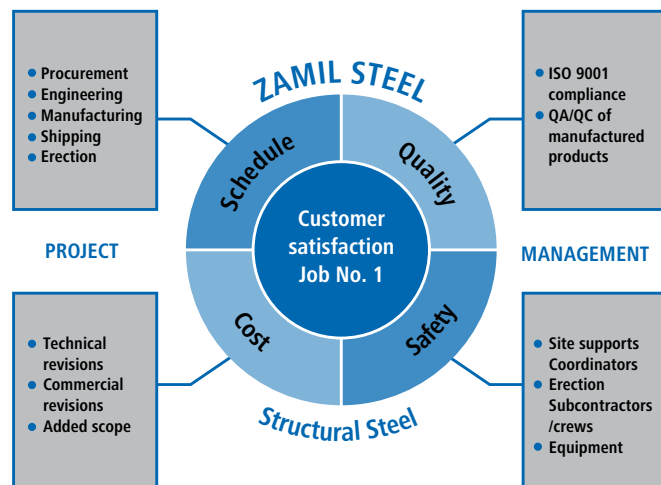

The Zamil Steel Structural Steel Certified and Systematic Process

1

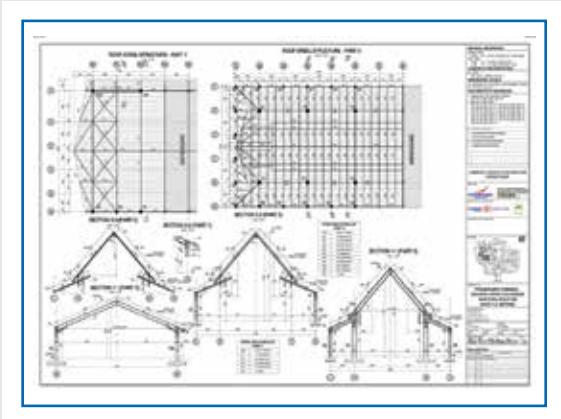

IFC DRAWINGS

2

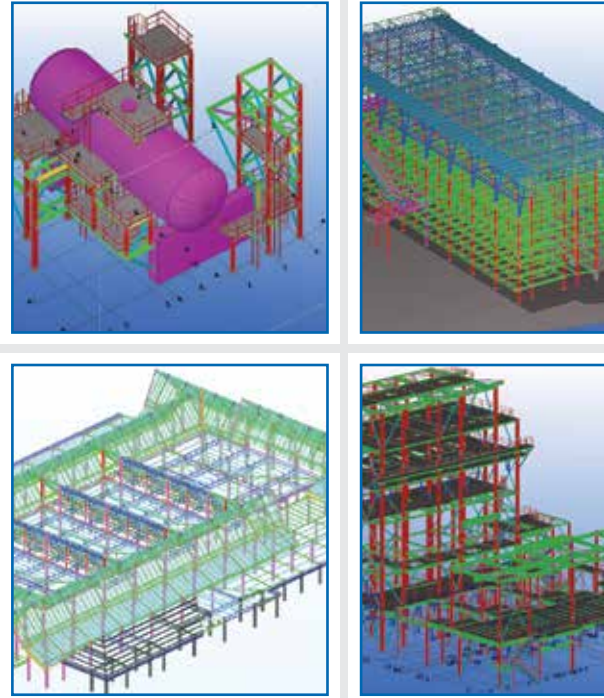

3D MODELING BY TEKLA



YOUR SATISFACTION

6



SITE ERECTION

5

3



EQUIPMENT CLASH CHECKING

CONNECTION DESIGN

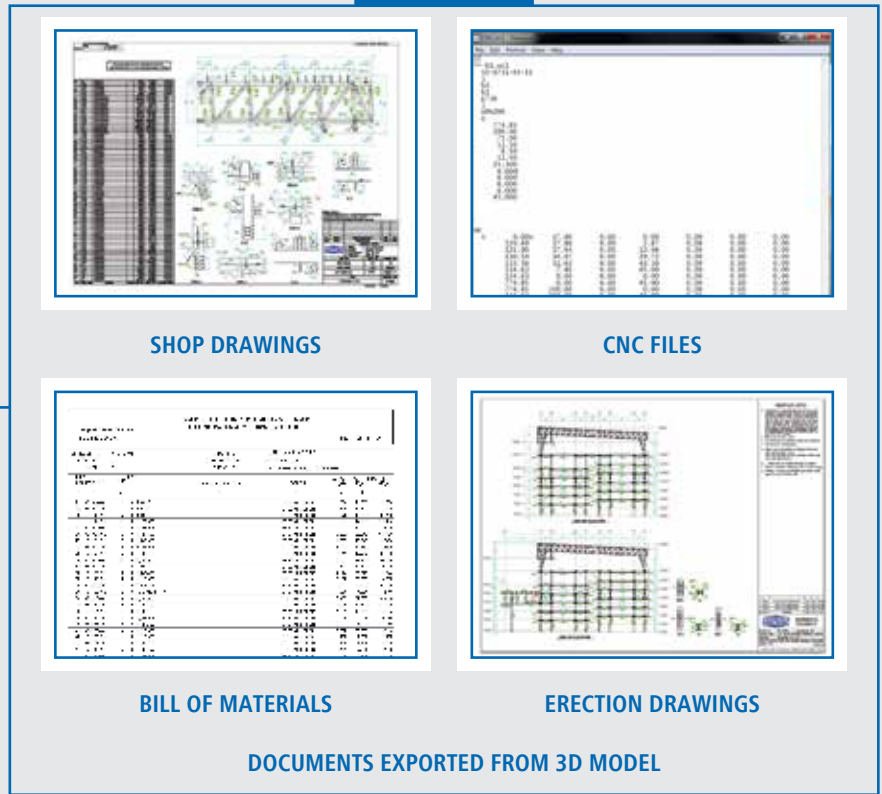

SHOP DRAWINGS

CNC FILES

BILL OF MATERIALS

ERECTION DRAWINGS

DOCUMENTS EXPORTED FROM 3D MODEL

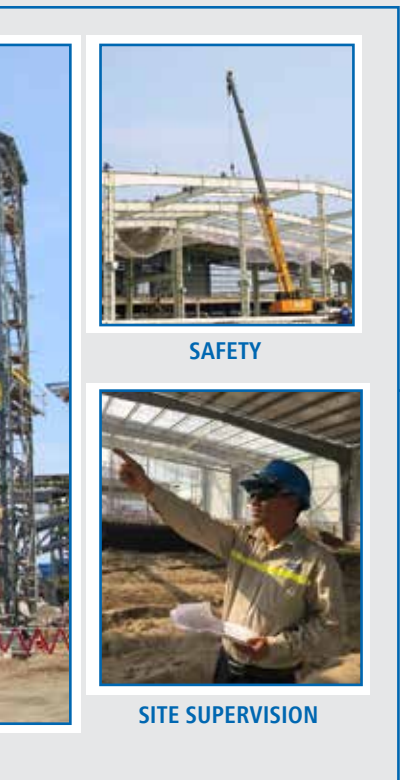

SAFETY

SITE SUPERVISION



CNC MACHINE

MATERIAL NESTING

STRICT QUALITY CONTROL

STATE OF THE ART FABRICATION

4

Examples of Structural Steel Applications

Zamil Steel Buildings Vietnam specializes in fabrication and erection of structural steel works in a wide range of applications such as:

High-rise Buildings	Commercial Centers	Hypermarkets, Shopping Malls
Exhibition Halls	Hotels	Schools
Airport Terminals	Aircraft Hangars	Sport Stadiums
Steel Rolling Mills	Heavy Industrial Plants	Power Plants
Petrochemical Plants	Refineries	Oil & Gas Plants
Built-up Girders and Columns	Equipment Support Structures	Military Utilities
Mining & Smelting	Building Materials	Ports





CHAPTER 3: EXAMPLES OF MAJOR PROJECTS



Cambodia



Malaysia



PEB projects by Zamil Steel

Thailand



Mauritius



Mongolia



Myanmar



Nigeria



Philippines



Thailand



Vietnam



Vietnam



Vietnam

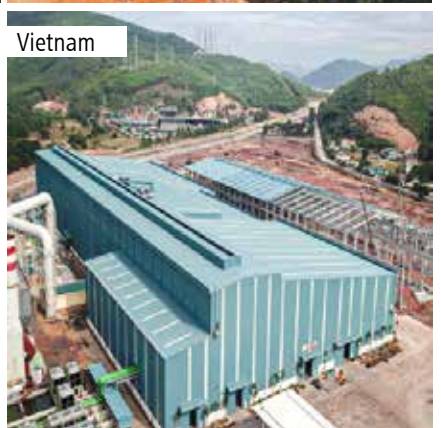



MaxSEAM® projects by Zamil Steel



Cambodia



Singapore

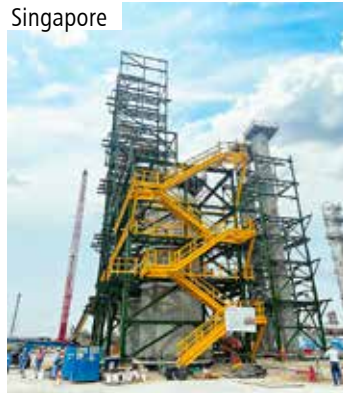

Malaysia

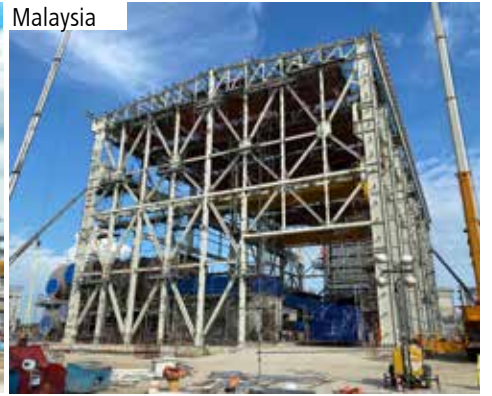

Vietnam



SS projects by Zamil Steel

Philippines



Philippines



Bangladesh



Singapore



Bangladesh



Vietnam



Vietnam



Japan





ZAMIL STEEL BUILDINGS VIETNAM CO., LTD

Head Office

14th floor, Keangnam Hanoi Landmark Tower,
Pham Hung Street, Nam Tu Liem District, Hanoi, Vietnam

Tel +84 (0) 24 3837 8522

Fax +84 (0) 24 3582 0801

Website www.zamilsteel.com.vn

Hanoi Factory

Noi Bai Industrial Zone, Quang Tien Village,
Soc Son District, Hanoi, Vietnam

Dong Nai Factory

Amata Industrial Park, Bien Hoa City, Dong Nai Province, Vietnam

Representatives Offices & Subsidiaries

Vietnam • Thailand • Philippines

Myanmar • Malaysia • Laos

Indonesia • Cambodia • Bangladesh

Other Factories

Saudi Arabia • Egypt • India • United Arab Emirates

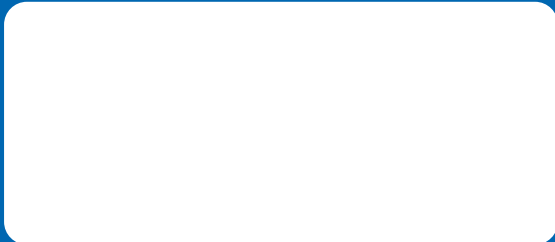

As of Apr 2023

This brochure contains Intellectual Property Rights; which are owned by Zamil Steel Buildings Vietnam Co., Ltd. (Zamil Steel). Copy or reproduction of this brochure or its parts may violate copyright of Zamil Steel. Zamil Steel reserves the right to change any information herein without notice. Please refer to Zamil Steel Representative Offices for updated information.